



MU IV

TIG - With or without filler wire, AVC, OSC

Open welding head

for welding of tube-to-tube joints,
tube to elbow joints...



POLYSOUDE

60 YEARS
ANNIVERSARY

MU IV Open welding head

for welding of tube-to-tube joints, tube to elbow joints...

A range of modular standard welding heads, perfectly adapted to your needs



Advantages

- ▶ Productivity increase of more than one third
- ▶ Easy to use
- ▶ Challenging applications, even with delicate materials, can be welded
- ▶ Quick to set-up according to the workload making variations in production capacity trouble free
- ▶ Precision engineered assemblies for a lifetime of trouble-free service

Resulting from 60 years' experience in mastering welding technologies

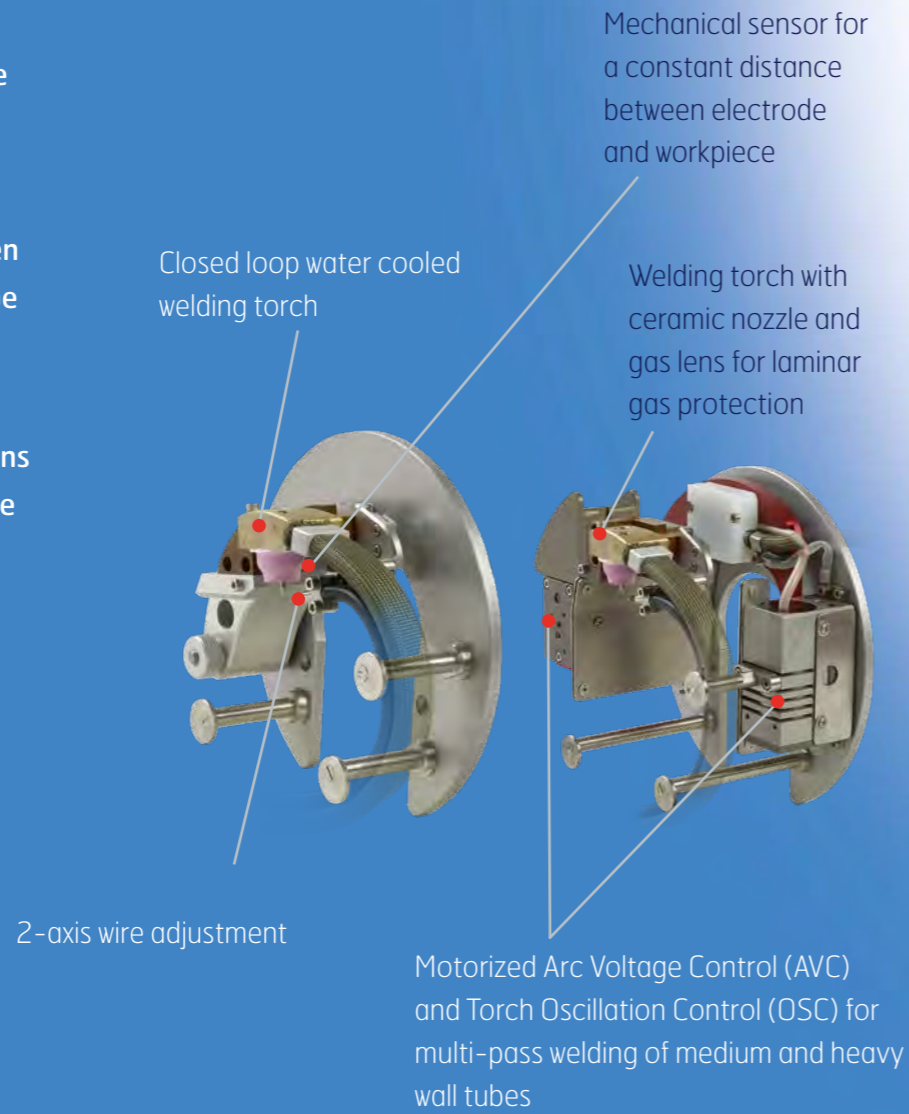

General characteristics



MU IV for use with external wire feeder

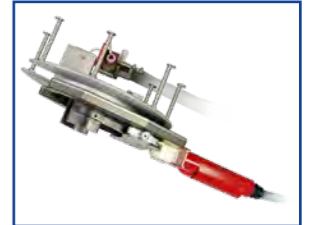

Drive motor with angle gearbox for reduced axial clearance



MU IV with integrated wire feeder



MU IV with AVC/OSC



Quick electrode change due to the torch tilting system for MU IV HW

Smart Welding Stations



▶ **P4**
170 A, "modular", portable, programming by PC or touch screen, single-phase power supply



▶ **P6**
300 in CW version or 550 A in HW version, "all applications", programming by PC or touch screen, with Arc Voltage Control (AVC) and Torch Oscillation Control (OSC), three-phase power supply



▶ **PC series**
300 to 550 A, modular design for perfect adaptation to your application. Interface for mechanised and robotic peripherals, three-phase power supply

Wire feeders



▶ **Polyfil series**
External portable wire feeders with spool protection

Technical specifications

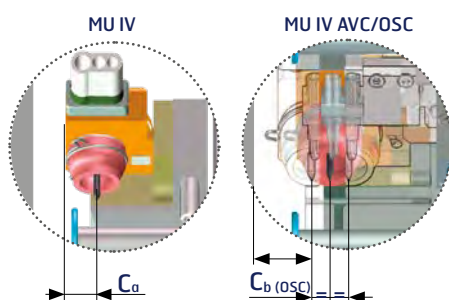
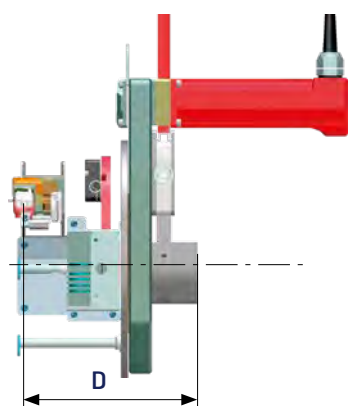
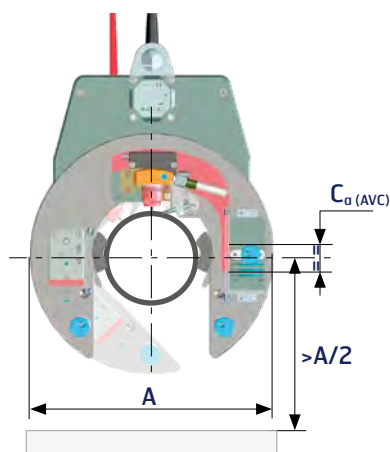

Cable length: 9m

MU IV without filler metal O.D. _{min.} /O.D. _{max.}			Ø A (mm)	D (mm)
MU IV 8/38 P	✓		126	96
MU IV 14/38 C		✓	126	79
MU IV 19/80 P	✓		172	97
MU IV 30/80 C		✓	172	88
MU IV 25/115 P	✓		215	101
MU IV 50/115 C		✓	215	92
MU IV 25/128 P	✓		240	99
MU IV 50/128 C		✓	240	108
MU IV 76/219 P	✓		440	178
MU IV 114/275 P	✓		500	172.5
MU IV 114/275 C		✓	500	178.5

MU IV with filler metal Ø _{min.} /Ø _{max.}			TIG CW	TIG HW	AVC/ OSC	Ø A (mm)	Amplitude		D (mm)
							Ca (mm)	Cb (mm)	
MU IV 8/38 AVC/OSC CW P	✓		✓		✓	142	20	20	160
MU IV 14/38 AVC/OSC CW C		✓	✓		✓	142	20	20	140
MU IV 14/38 CW P - reduced plate	✓		✓			96	5	-	96
MU IV 14/38 AVC/OSC CW C - reduced plate		✓	✓		✓	132	20	20	140
MU IV 14/38 CW C - reduced plate		✓	✓			96	5	-	79
MU IV 30/51 AVC/OSC CW C - reduced plate		✓	✓		✓	145	20	20	152
MU IV 30/58 CW C - reduced plate		✓	✓			122	5	89	89
MU IV 30/60 AVC/OSC HW C		✓		✓	✓	280	20	30	160
MU IV 30/64 AVC/OSC CW C - reduced plate		✓	✓		✓	158	20	20	152
MU IV 19/80 AVC/OSC CW P	✓		✓		✓	200	20	20	146
MU IV 30/80 AVC/OSC CW C		✓	✓		✓	200	20	20	136
MU IV 25/115 AVC/OSC CW P	✓		✓		✓	235	20	20	149
MU IV 50/115 AVC/OSC CW C		✓	✓		✓	235	20	20	138
MU IV 42/128 AVC/OSC CW P	✓		✓		✓	340	20	30	144
MU IV 50/128 AVC/OSC CW C		✓	✓		✓	340	20	30	158
MU IV 76/219 AVC/OSC CW P	✓		✓		✓	503	20	30	197
MU IV 76/219 AVC/OSC HW P	✓			✓	✓	410	20	30	180
MU IV 76/219 AVC/OSC HW C		✓		✓	✓	580	40	40	217
MU IV 114/275 AVC/OSC CW P	✓		✓		✓	530	20	30	174
MU IV 114/275 AVC/OSC CW C		✓	✓		✓	530	20	30	199

Dimensions in mm

Options and accessories

- On board wire feeder for 1.5kg spool or external POLYFIL wire feeders for spool up to 15kg with wire accessories
- Clamp shells (C-clamping system) for all tube and pipe O.D.'s
- Balancers
- Extension cable (15m)
- Dual welding head switch box
- Compact shipping case for transport and storage
- Tungsten electrodes, pre-sharpened and pre-cut

 Adapted for all your applications!

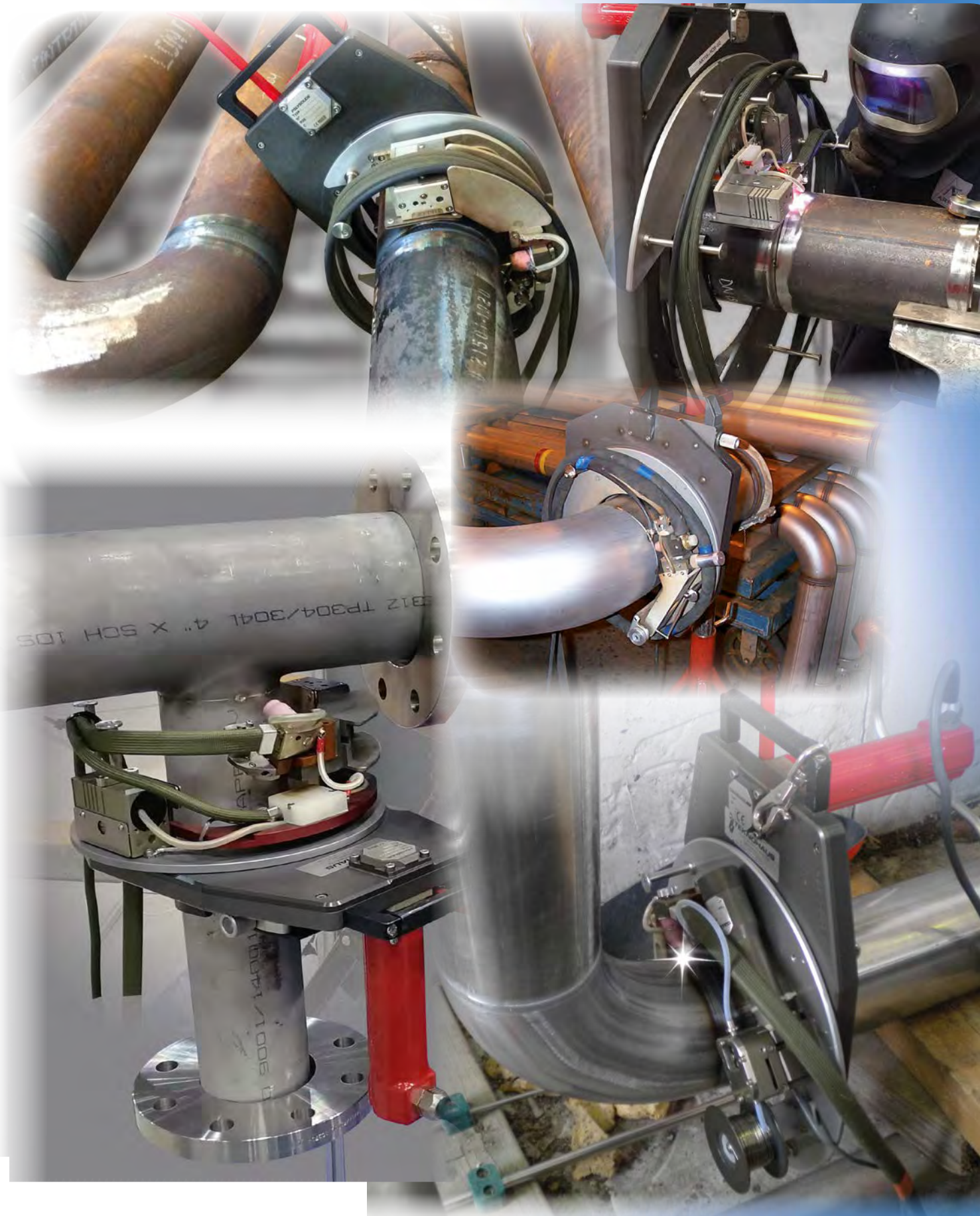

POLYSOUDE : Related services

► Guidance and technical support

A welding application specialist in your area will advise you on the welding process and appropriate equipment for your application.

► Commissioning / Training

A complete training program will enable you to start using the equipment immediately and in the best way possible.

► Maintenance / Repair

Maintenance and repair operations can be carried out at the Polysoude plant as well as on site by our service network.

► Rental service

Increase the flexibility of your production! A large range of equipment is available for rental from our hire fleet.

Your partners worldwide

ARGENTINA
POLYSOUDE S.A.S.
☎ +33 (0) 2 40 68 11 00
info@polysoude.com

AUSTRALIA
POLYSOUDE S.A.S.
☎ +33 (0) 2 40 68 11 00
info@polysoude.com

AUSTRIA
POLYSOUDE AUSTRIA GmbH
☎ +43 (0) 3613 200 36
austria@polysoude.at

BAHRAIN
SALWO TRADING Ltd.
☎ +971 (0) 48 81 05 91
salwo@emirates.net.ae

BELGIUM
POLYSOUDE BENELUX BV
☎ +31 (0) 653 84 23 36
benelux@polysoude.com

POLYSOUDE BENELUX BV (SERVICE)
☎ +31 (0) 653 38 85 58
service.benelux@polysoude.com

BRAZIL
POLYSOUDE S.A.S.
☎ +33 (0) 2 40 68 11 00
info@polysoude.com

BULGARIA
KARWELD FOOD
☎ +359 (0) 29 73 32 15
Karweld@bg400.bg

CANADA
MAG Tool – West
EDMONTON – ALBERTA
☎ +1 800 661 9983
magtool@magtool.com

MAG Tool – East
TORONTO – ONTARIO
☎ +1 905 699 – 5016
ray@magtool.com

CHINA
POLYSOUDE SHANGHAI CO. Ltd
☎ +86 (0) 21 64 09 78 26
jm.pan@polysoude.com.cn

CROATIA
EUROARC D.O.O.
☎ +385 (0) 1 2 40 60 77
euroarc@euroarc.hr

CZECH REPUBLIC
POLYSOUDE CZ
☎ +420 602 60 28 55
m.matousek@polysoude.cz

DENMARK
HALL & CO. INDUSTRI
☎ +45 (0) 39 56 06 76
p.lorenzen@polysoude.com

EGYPT
STEEL TECH
☎ +2 02 22 02 99 79
info@steelttecheg.com

ESTONIA
POLYSOUDE S.A.S.
☎ +33 (0) 2 40 68 11 00
info@polysoude.com

FINLAND
SUOMEN TEKNOHAUS OY
☎ +358 (0) 927 47 2 10
info@teknohaus.fi

FRANCE
POLYSOUDE S.A.S.
☎ +33 (0) 2 40 68 11 00
info@polysoude.com

GERMANY
POLYSOUDE DEUTSCHLAND GmbH
DUSSLINGEN
☎ +49 (0) 7072 60076 0
info@polysoude.de

GREECE
POLYSOUDE S.A.S.
☎ +33 (0) 2 40 68 11 00
info@polysoude.com

JAPAN
GMT CO Ltd – KAWASAKI
☎ +81 (0) 44 222 6751
gmt@e-gmt.co.jp

GMT CO Ltd – OSAKA
☎ +81 (0) 798 35 6751
gmt.kansai@e-gmt.co.jp

JORDAN
POLYSOUDE S.A.S.
☎ +33 (0) 2 40 68 11 00
info@polysoude.com

KUWAIT
SALWO TRADING Ltd.
☎ +971 (0) 48 81 05 91
salwo@emirates.net.ae

LATVIA
POLYSOUDE S.A.S.
☎ +33 (0) 2 40 68 11 00
info@polysoude.com

OMAN
SALWO TRADING Ltd.
☎ +971 (0) 48 81 05 91
salwo@emirates.net.ae

PAKISTAN
POLYSOUDE S.A.S.
☎ +33 (0) 2 40 68 11 00
info@polysoude.com

PHILIPPINES
POLYSOUDE S.A.S.
☎ +33 (0) 2 40 68 11 00
info@polysoude.com

POLAND
UNIDAWELD – BEDZIN
☎ +48 (0) 32 267 05 54
dariusz.szota@unidaweld.pl

SUPRA ELCO
☎ +48 500 004 804
jacek.szulc@supraelco.waw.pl

SINGAPORE
POLYSOUDE SINGAPORE OFFICE
☎ +65 0734 8452
Jmpan@singnet.com.sg

SLOVAKIA
POLYSOUDE CZ
☎ +420 602 60 28 55
m.matousek@polysoude.cz

SOUTH AFRICA
POLYSOUDE S.A.S.
☎ +33 (0) 2 40 68 11 00
info@polysoude.com

SOUTH KOREA
CHEMIKO CO Ltd
☎ +82 (0) 2 567 5335
chemiko@chemiko.net

SPAIN
POLYSOUDE S.A.S.
☎ +33 (0) 2 40 68 11 00
info@polysoude.com

SWEDEN
HALL & CO. INDUSTRI
☎ +45 (0) 39 56 06 76
p.lorenzen@polysoude.com

SWITZERLAND
POLYSOUDE (SWITZERLAND) Inc.
☎ +41 (0) 43 243 50 80
contact@polysoude.ch

TAIWAN R.O.C.
FIRST ELITE ENT. CO. Ltd
☎ +886 (0) 287 97 88 99
auto.pipe@msa.hinet.net

THAILAND
POLYSOUDE S.A.S.
☎ +33 (0) 2 40 68 11 00
info@polysoude.com

TURKEY
EGE MAKINE
☎ +90 (0) 212 237 40 40
info@egemakine.com

UNITED ARAB EMIRATES
SALWO TRADING Ltd.
☎ +971 (0) 48 81 05 91
salwo@emirates.net.ae

UNITED KINGDOM
POLYSOUDE UK
☎ +44 (0) 1942 820 935
admin.uk@polysoude.com

UKRAINE
POLYSOUDE RUSSIA
☎ +7 495 564 86 81
info@polysoude.ru

UNITED STATES
ASTRO ARC POLYSOUDE Inc.
☎ +1818 (859) 7600
sales@astroarc.com

VENEZUELA
ENRIVA C.A.
☎ +58 (0) 412 34 82 602
enriva@gmail.com

VIETNAM
ANH DUONG IT Ltd
☎ +84 22 159 532
an@anhduongco.com



HUNGARY
POLYWELD Kft.
☎ +36 (0) 20 29 88 708
polyweld@polyweld.hu

INDIA
POLYSOUDE INDIA
☎ +91 (0) 20 271 27 678
ab.kulkarni@polysoude.in

INDONESIA
POLYSOUDE S.A.S.
☎ +33 (0) 2 40 68 11 00
info@polysoude.com

IRAN
STD CO
☎ +98 21 88525206-7
najco_ir@hotmail.com

ISRAEL
POLYSOUDE S.A.S.
☎ +33 (0) 2 40 68 11 00
info@polysoude.com

ITALY
POLYSOUDE ITALIA SRL
☎ +39 02 93 79 90 94
info@polysoude.it

LITHUANIA
POLYSOUDE S.A.S.
☎ +33 (0) 2 40 68 11 00
info@polysoude.com

MALAYSIA
POLYSOUDE S.A.S.
☎ +33 (0) 2 40 68 11 00
info@polysoude.com

NETHERLANDS
POLYSOUDE BENELUX BV
☎ +31 (0) 653 84 23 36
benelux@polysoude.com

POLYSOUDE BENELUX BV (SERVICE)
☎ +31 (0) 653 38 85 58
service.benelux@polysoude.com

NEW ZEALAND
POLYSOUDE S.A.S.
☎ +33 (0) 2 40 68 11 00
info@polysoude.com

NORWAY
TEMA NORGE AS
☎ +47 (0) 51 69 25 00
tema@tema-norge.no

PORTUGAL
POLYSOUDE S.A.S.
☎ +33 (0) 2 40 68 11 00
info@polysoude.com

QATAR
SALWO TRADING Ltd.
☎ +971 (0) 48 81 05 91
salwo@emirates.net.ae

REPUBLIC OF IRELAND
POLYSOUDE UK
☎ +44 (0) 1942 820 935
admin.uk@polysoude.com

ROMANIA
DEBISUD CONCEPT S.R.L.
☎ +40 (0) 255 21 57 85
office@debisud.ro

RUSSIA + C.I.S.
POLYSOUDE RUSSIA
☎ +7 495 564 86 81
info@polysoude.ru

SAUDI ARABIA
SALWO TRADING Ltd.
☎ +971 (0) 48 81 05 91
salwo@emirates.net.ae



POLYSOUDE
THE ART OF WELDING

Find us on



Polysoude S.A.S.
Z.I. du Bois Briand • 2 rue Paul Beaupère
F - 44300 NANTES

☎ +33 (0) 2 40 68 11 00 • 📠 +33 (0) 2 40 68 11 88
🌐 www.polysoude.com • ✉ info@polysoude.com