

PROMOCJA NA POLEROWANE PŁYTKI DO TOCZENIA ALUMINIUM

	Oznaczenie	Cena netto PLN/szt.
	CCGT 060202 WLHC HN10	20,00
	CCGT 060204 WLHC HN10	20,00
	CCGT 09T302 WLHC HN10	21,00
	CCGT 09T304 WLHC HN10	21,00
	CCGT 09T308 WLHC HN10	21,00
	DCGT 070202 WLHC HN10	20,00
	DCGT 070204 WLHC HN10	20,00
	DCGT 11T302 WLHC HN10	21,00
	DCGT 11T304 WLHC HN10	21,00
	DCGT 11T308 WLHC HN10	21,00
	VCGT 160402 WLHC HN10	27,00
	VCGT 160404 WLHC HN10	27,00
	VCGT 160408 WLHC HN10	27,00
	TCGT 110202 WLHC HN10	20,00
	TCGT 110204 WLHC HN10	20,00
	TCGT 16T302 WLHC HN10	21,00
	TCGT 16T304 WLHC HN10	21,00
	TCGT 16T308 WLHC HN10	21,00
	WNMG 080404 WLH HN10	22,00
	WNMG 080408 WLH HN10	22,00

Płytki do toczenia, przecinania, frezowania i wiercenia (dostępne również w innych geometriach, pokryciach i z innymi promieniami naroża)

Oznaczenie	Zastosowanie	Cena netto PLN/szt.
CCMT 060204 WM HP20	Stal	20,00
CCMT 060204 WM HM25	Stal nierdzewna	20,00
CCMT 09T304 WM HP20	Stal	21,00
CCMT 09T304 WM HM25	Stal nierdzewna	21,00
DCMT 070204 WM HP20	Stal	20,00
DCMT 070204 WM HM25	Stal nierdzewna	20,00
DCMT 11T304 WM HP20	Stal	21,00
DCMT 11T304 WM HM25	Stal nierdzewna	21,00
VCMT 160404 WM HP20	Stal	27,00
VCMT 160404 WM HM25	Stal nierdzewna	27,00
WNMG 080408 WM HP20	Stal	22,00
WNMG 080408 WMM HM25	Stal nierdzewna	22,00
CNMG 120408 WM HP20	Stal	22,00
CNMG 120408 WMM HM25	Stal nierdzewna	22,00
DNMG 150608 WM HP20	Stal	27,00
DNMG 150608 WMM HM25	Stal nierdzewna	27,00
MGMN 200-M HMP25	Uniwersalna	26,00
MGMN 300-M HMP25	Uniwersalna	27,00
MGMN 400-M HMP25	Uniwersalna	28,00
APKT 1003PDSR-30 HMP25	Uniwersalna	20,00
R390-11T308-PM HMP25	Uniwersalna	30,00
ZNGX 080608-FR BM HMP25	(XNEX) Uniwersalna	50,00
LNMU 0603R-M HMP25	(BLMP) Uniwersalna	30,00
SPMG 050204 ZV HMP25	Uniwersalna	28,00
SPMG 060204 ZV HMP25	Uniwersalna	28,00
SPMG 07T308 ZV HMP25	Uniwersalna	29,00
SPMG 090408 ZV HMP25	Uniwersalna	30,00
SPMG 110408 ZV HMP25	Uniwersalna	31,00

Noże do toczenia zewnętrznego na płytki DNMG



Cooling accessories are optional / See Page 297 for cooling accessory.
Soğutma ekipmanları opsiyoneldir / Bkz. Sayfa 297 Soğutma aksesuarları için

Ordering Code		Item Designation	Price	Master Insert*
<i>Direction</i>		<i>TDJN R/L-JT (93)</i>	<i>EURO</i>	
<i>Right</i>	<i>Left</i>			
SM56022	SM56039	TDJN R/L 2525 M15-JT	103 €	DNM.1506..



Ordering Code		Item Designation	Price	Master Insert*
<i>Direction</i>		<i>TDJN R/L (93)</i>	<i>EURO</i>	
<i>Right</i>	<i>Left</i>			
SM26766	SM00407	TDJN R/L 1616 H11	50 €	DNM.1104..
SM00353	SM00360	TDJN R/L 2020 K11	56 €	
SM00346	SM00377	TDJN R/L 2525 M11	59 €	DNM.1504..
SM29675	SM34006	TDJN R/L 2020 K1504	56 €	
SM29682	SM33993	TDJN R/L 2525 M1504	59 €	DNM.1506..
SM33948	SM33986	TDJN R/L 3232 P1504	69 €	
SM00421	SM00469	TDJN R/L 2020 K15	56 €	DNM.1506..
SM00438	SM00483	TDJN R/L 2525 M15	59 €	
SM00506	SM00490	TDJN R/L 3232 P15	69 €	
SM00520	SM00513	TDJN R/L 4040 S15	108 €	

Noże do toczenia zewnętrznego na płytki CNMG



Cooling accessories are optional / See Page 297 for cooling accessory.
Soğutma ekipmanları opsiyoneldir / Bkz. Sayfa 297 Soğutma aksesuarları için

Ordering Code		Item Designation	Price	Master Insert*
<i>Direction</i>		<i>TCLN R/L-JT (95)</i>	<i>EURO</i>	
<i>Right</i>	<i>Left</i>			
SM56060	SM56077	TCLN R/L 2525 M12-JT	103 €	CNM.1204..



Ordering Code		Item Designation	Price	Master Insert*
<i>Direction</i>		<i>TCLN R/L (95)</i>	<i>EURO</i>	
<i>Right</i>	<i>Left</i>			
SM00210	SM55377	TCLN R/L 2525 M09	59 €	CNM.0903..
SM00025	SM00032	TCLN R/L 2020 K12	56 €	
SM00056	SM00063	TCLN R/L 2525 M12	59 €	CNM.1204..
SM00087	SM00094	TCLN R/L 3232 P12	69 €	
SM27091	SM27107	TCLN R/L 4040 S12	111 €	CNM.1606..
SM00148	SM00155	TCLN R/L 2525 M16	69 €	
SM00179	SM00186	TCLN R/L 3232 P16	77 €	CNM.1909..
SM00209	SM00193	TCLN R/L 4040 S16	117 €	
SM00261	SM00278	TCLN R/L 3232 P19	91 €	
SM00285	SM00292	TCLN R/L 4040 S19	121 €	

Noże do toczenia zewnętrznego na płytki WNMG



Ordering Code		Item Designation	Price	Master Insert*
<i>Direction</i>		<i>TWLN R/L-JT (95)</i>	<i>EURO</i>	
<i>Right</i>	<i>Left</i>			
SM56046	SM56053			

Cooling accessories are optional / See Page 297 for cooling accessory.
Soğutma ekipmanları opsiyoneldir / Bkz. Sayfa 297 Soğutma aksesuarları için



Ordering Code		Item Designation	Price	Master Insert*
<i>Direction</i>		<i>TWLN R/L (95)</i>	<i>EURO</i>	
<i>Right</i>	<i>Left</i>			
SM01107	SM01114			
SM01121	SM01138	TWLN R/L 2020 K06	56 €	
SM01145	SM01152	TWLN R/L 2525 M06	59 €	WNM.0804..
SM01176	SM01169	TWLN R/L 2020 K08	56 €	
SM01206	SM01183	TWLN R/L 2525 M08	59 €	
SM01213	SM01190	TWLN R/L 3232 P08	69 €	
SM01220	SM01237	TWLN R/L 4040 S08	108 €	

Noże do toczenia zewnętrznego na płytki VCMT



Ordering Code		Item Designation	Price	Master Insert*
<i>Direction</i>		<i>SVJC R/L (93)</i>	<i>EURO</i>	
<i>Right</i>	<i>Left</i>			
SM26971	SM26995			
SM20962	SM27008	SVJC R/L 2020 K11	43 €	
SM23611	SM23635	SVJC R/L 2020 K16	45 €	VCM. 1604..
SM23604	SM23628	SVJC R/L 2525 M16	46 €	
SM26988	SM27015	SVJC R/L 3232 P16	56 €	



Ordering Code		Item Designation	Price	Master Insert*
<i>Direction</i>		<i>SVVCN (72.5)</i>	<i>EURO</i>	
<i>Neutral</i>				
SM45026	SM44418			
SM44401	SM44401	SVVCN 2020 K16	45 €	
SM40199	SM45064	SVVCN 2525 M16	46 €	VCM. 1604..
SM45064	SM45064	SVVCN 3232 P16	56 €	

Noże do toczenia wewnętrznego z chłodzeniem na płytki DCMT



Ordering Code		Item Designation	Price	Master Insert*
<i>Direction</i>		<i>A-SDUC R/L(93)</i>	<i>EURO</i>	
<i>Right</i>	<i>Left</i>			
SM36093	SM36109	A10H SDUC R/L-07	36 €	DCM. 0702..
SM36116	SM36123	A12H SDUC R/L-07	40 €	
SM36130	SM36147	A16M SDUC R/L-07	45 €	
SM36154	SM36161	A16M SDUC R/L-11	46 €	DCM. 11T3..
SM36178	SM36185	A20P SDUC R/L-11	50 €	
SM36192	SM36208	A25R SDUC R/L-11	57 €	
SM36215	SM36222	A32S SDUC R/L-11	90 €	



Ordering Code		Item Designation	Price	Master Insert*
<i>Direction</i>		<i>A-SDQC R/L(107.5)</i>	<i>EURO</i>	
<i>Right</i>	<i>Left</i>			
SM36239	SM36246	A10H SDQC R/L-07	36 €	DCM. 0702..
SM36253	SM36260	A12H SDQC R/L-07	40 €	
SM36277	SM36284	A16M SDQC R/L-07	45 €	
SM36291	SM36307	A16M SDQC R/L-11	46 €	DCM. 11T3..
SM36314	SM36321	A20P SDQC R/L-11	50 €	
SM36338	SM36345	A25R SDQC R/L-11	57 €	
SM36352	SM36369	A32S SDQC R/L-11	90 €	

Noże do toczenia wewnętrznego z chłodzeniem na płytki CCMT





Ordering Code		Item Designation	Price	Master Insert*
<i>Direction</i>		<i>A-SCLC R/L(95)</i>	<i>EURO</i>	
<i>Right</i>	<i>Left</i>			
SM36376	SM36383	A08H SCLC R/L-06	36 €	CCM. 0602..
SM36390	SM36406	A10H SCLC R/L-06	36 €	
SM36413	SM36420	A12H SCLC R/L-06	40 €	
SM36437	SM36444	A16M SCLC R/L-09	46 €	CCM. 09T3..
SM36451	SM36468	A20P SCLC R/L-09	50 €	
SM36475	SM36482	A25R SCLC R/L-09	57 €	
SM36499	SM36505	A32S SCLC R/L-09	90 €	

Noże do kanałków zewnętrznych na płytki MGMN



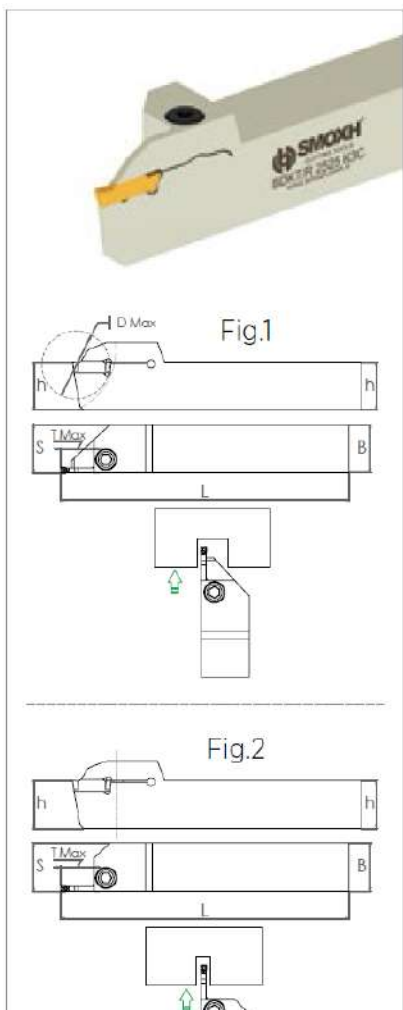

Ordering Code		Item Designation	Price	Master Insert
<i>Direction</i>		<i>BDKT R/L-MGM</i>	<i>EURO</i>	
<i>Right</i>	<i>Left</i>			
SM56183	SM56190	2525 BDKT R/L-K3C t max:22-JC	135 €	MGM. 3C
SM56206	SM56213	2525 BDKT R/L-K4C t max:22-JC	135 €	MGM. 4C



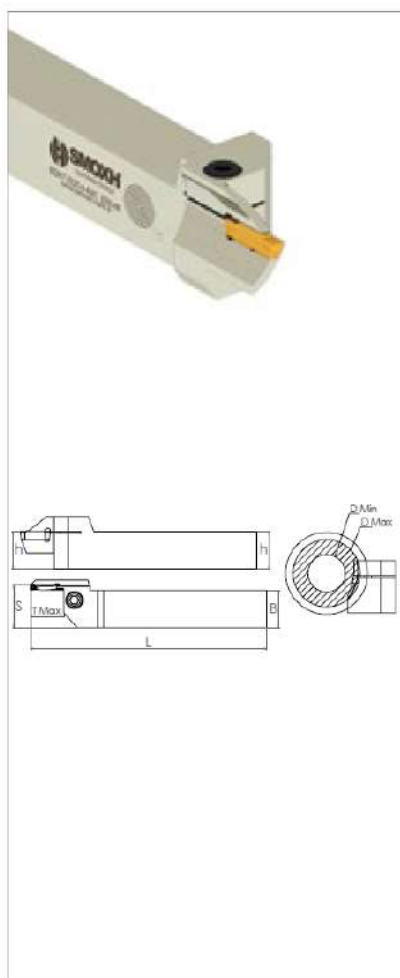

Ordering Code		Item Designation	Master Insert		
<i>Direction</i>		<i>BDKT R/L-MGM</i>	<i>Fig.</i>	<i>EURO</i>	
<i>Right</i>	<i>Left</i>				
SM09493	SM09691	1212 BDKT R/L-K2C t max:15	1	62 €	MGM. 2C
SM09479	SM09660	1616 BDKT R/L-K2C t max:18	1	67 €	
SM09455	SM09653	2020 BDKT R/L-K2C t max:18	1	69 €	
SM27411	SM38851	2020 BDKT R/L-K2C t max:12	1	69 €	
SM09462	SM09677	2525 BDKT R/L-K2C t max:18	1	73 €	MGM. 2.5C
SM09486	SM09684	3232 BDKT R/L-K2C t max:18	1	83 €	
SM47747	SM47754	2020 BDKT R/L-K2.5C t max:18	1	69 €	MGM. 3C
SM47761	SM47778	2525 BDKT R/L-K2.5C t max:18	1	73 €	
SM09547	SM09745	1212 BDKT R/L-K3C t max:18	1	62 €	MGM. 3C
SM09523	SM09714	1616 BDKT R/L-K3C t max:18	1	67 €	
SM09509	SM09707	2020 BDKT R/L-K3C t max:20	1	69 €	
SM57258	SM57265	2020 BDKT R/L-K3C-T t max:20	2	69 €	
SM09516	SM09721	2525 BDKT R/L-K3C t max:22	1	73 €	
SM57173	SM57180	2525 BDKT R/L-K3C-T t max:22	2	73 €	
SM24601	SM25141	2525 BDKT R/L-K3C t max:25	1	83 €	
SM57197	SM57203	2525 BDKT R/L-K3C-T t max:25	2	83 €	
SM24625	SM25134	2525 BDKT R/L-K3C t max:40	1	123 €	
SM09530	SM09738	3232 BDKT R/L-K3C t max:22	1	83 €	
SM09554	SM09752	2020 BDKT R/L-K4C t max:20	1	69 €	MGM. 4C
SM57272	SM57289	2020 BDKT R/L-K4C-T t max:20	2	69 €	
SM27428	SM38844	2020 BDKT R/L-K4C t max:25	1	69 €	
SM09561	SM09769	2525 BDKT R/L-K4C t max:22	1	73 €	
SM24618	SM25127	2525 BDKT R/L-K4C t max:25	1	83 €	MGM. 5C
SM24687	SM25110	2525 BDKT R/L-K4C t max:40	1	123 €	
SM09578	SM09776	3232 BDKT R/L-K4C t max:22	1	83 €	MGM. 5C
SM09585	SM09783	2020 BDKT R/L-K5C t max:20	1	69 €	
SM09592	SM09790	2525 BDKT R/L-K5C t max:25	1	73 €	
SM37830	SM37847	2525 BDKT R/L-K5C t max:40	1	123 €	
SM09608	SM09806	3232 BDKT R/L-K5C t max:25	1	83 €	

Noże do kanalków czolowych na płytki MGMN

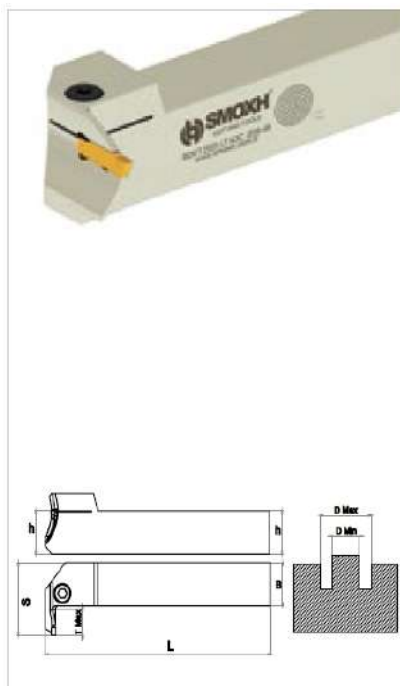

Ordering Code	Item Designation	Price	Master Insert
<i>Direction</i>	A TYPE FACE GROOVING	<i>EURO</i>	
<i>Right</i>	BDKT-A MGM.		
SM10543	2525 BDKT-A K3C (Ø24-36) t max:17	102 €	MGM. 3C
SM10567	2525 BDKT-A K3C (Ø36-48) t max:17	102 €	
SM10550	2525 BDKT-A K3C (Ø48-70) t max:17	102 €	
SM10536	2525 BDKT-A K3C (Ø70-110) t max:17	102 €	
SM10512	2525 BDKT-A K3C (Ø100-150) t max:17	102 €	
SM10529	2525 BDKT-A K3C (Ø150-200) t max:17	102 €	
SM39643	2525 BDKT-A K3C (Ø200-350) t max:17	102 €	
SM39650	2525 BDKT-A K3C (Ø300-500) t max:17	102 €	MGM. 4C
SM10581	2525 BDKT-A K4C (Ø24-36) t max:22	102 €	
SM10604	2525 BDKT-A K4C (Ø36-48) t max:22	102 €	
SM10598	2525 BDKT-A K4C (Ø48-70) t max:22	102 €	
SM10574	2525 BDKT-A K4C (Ø70-110) t max:22	102 €	
SM10628	2525 BDKT-A K4C (Ø100-150) t max:22	102 €	
SM10611	2525 BDKT-A K4C (Ø150-200) t max:22	102 €	
SM39667	2525 BDKT-A K4C (Ø200-350) t max:22	102 €	MGM. 5C
SM39674	2525 BDKT-A K4C (Ø300-500) t max:22	102 €	
SM10635	2525 BDKT-A K5C (Ø36-48) t max:25	102 €	
SM10659	2525 BDKT-A K5C (Ø48-70) t max:25	102 €	
SM10666	2525 BDKT-A K5C (Ø70-110) t max:25	102 €	
SM10673	2525 BDKT-A K5C (Ø100-150) t max:25	102 €	
SM10680	2525 BDKT-A K5C (Ø150-200) t max:25	102 €	
SM39681	2525 BDKT-A K5C (Ø200-350) t max:25	102 €	
SM39803	2525 BDKT-A K5C (Ø300-500) t max:25	102 €	







Ordering Code	Item Designation	Price	Master Insert
<i>Direction</i>	L TYPE FACE GROOVING	<i>EURO</i>	
<i>Right</i>	BDKT-LT MGM.		
SM37854	2525 BDKT-LT K3C (Ø24-36) t max:17	102 €	MGM. 3C
SM34624	2525 BDKT-LT K3C (Ø36-48) t max:17	102 €	
SM34631	2525 BDKT-LT K3C (Ø48-70) t max:17	102 €	
SM34648	2525 BDKT-LT K3C (Ø70-110) t max:17	102 €	
SM34655	2525 BDKT-LT K3C (Ø100-150) t max:17	102 €	
SM34662	2525 BDKT-LT K3C (Ø150-200) t max:17	102 €	
SM39766	2525 BDKT-LT K3C (Ø200-350) t max:17	102 €	
SM39773	2525 BDKT-LT K3C (Ø300-500) t max:17	102 €	MGM. 4C
SM37861	2525 BDKT-LT K4C (Ø36-48) t max:20	102 €	
SM37878	2525 BDKT-LT K4C (Ø48-70) t max:20	102 €	
SM34679	2525 BDKT-LT K4C (Ø70-110) t max:20	102 €	
SM34686	2525 BDKT-LT K4C (Ø100-150) t max:20	102 €	
SM34693	2525 BDKT-LT K4C (Ø150-200) t max:20	102 €	
SM39780	2525 BDKT-LT K4C (Ø200-350) t max:20	102 €	
SM39797	2525 BDKT-LT K4C (Ø300-500) t max:20	102 €	

Noże do kanalków wewnętrznych na płytki MGMN

	Ordering Code		Item Designation	Price	Fig.	Master Insert*
	Direction		BIKT R/L MGM.-KRLY	EURO		
	Right	Left				
	SM51478	SM51485	BIKT R/L 16-K1.5C t max:4	62 €	1	MGM. 1.5C
	SM51522	SM51515	BIKT R/L 20-K1.5C t max:6	65 €	1	
	SM11151	SM11298	BIKT R/L 16-K2C t max:4	62 €	1	MGM. 2C
	SM11168	SM11304	BIKT R/L 20-K2C t max:6	65 €	1	
	SM11175	SM11311	BIKT R/L 25-K2C t max:7	70 €	1	MGM. 3C
	SM11199	SM11335	BIKT R/L 20-K3C t max:6	65 €	1	
	SM11205	SM11342	BIKT R/L 25-K3C t max:7	70 €	1	MGM. 3C
	SM59597	SM59641	BEKT R/L 25-K3C t max:10-IJ	85 €	2	
	SM59603	SM59658	BEKT R/L 25-K3C t max:7 D25-IJ	85 €	3	MGM. 3C
	SM11182	SM11359	BIKT R/L 32-K3C t max:8	75 €	1	
	SM59610	SM59665	BEKT R/L 32-K3C t max:10-IJ	105 €	2	MGM. 4C
	SM11212	SM11328	BIKT R/L 40-K3C t max:10	105 €	1	
	SM11229	SM11366	BIKT R/L 20-K4C t max:6	62 €	1	MGM. 4C
	SM11236	SM11373	BIKT R/L 25-K4C t max:7	70 €	1	
	SM59627	SM59672	BEKT R/L 25-K4C t max:10-IJ	85 €	2	MGM. 4C
	SM11243	SM11380	BIKT R/L 32-K4C t max:8	75 €	1	
	SM59634	SM59689	BEKT R/L 32-K4C t max:10-IJ	105 €	2	MGM. 4C
	SM11250	SM11397	BIKT R/L 40-K4C t max:10	105 €	1	
	SM25684	SM25646	BIKT R/L 50-K4C t max:15	265 €	1	MGM. 5C
	SM11267	SM11403	BIKT R/L 25-K5C t max:7	70 €	1	
	SM11274	SM11410	BIKT R/L 32-K5C t max:8	75 €	1	MGM. 5C
	SM11281	SM11427	BIKT R/L 40-K5C t max:10	105 €	1	
	SM25677	SM25639	BIKT R/L 50-K5C t max:15	265 €	1	MGM. 5C
	SM55599	SM55612	BIKT R/L 32-K6C t max:8	73 €	1	
	SM55605	SM55629	BIKT R/L 40-K6C t max:10	105 €	1	MGM. 6C
	SM25660	SM25622	BIKT R/L 50-K6C t max:15	265 €	1	
	SM55636	SM55643	BIKT R/L 40-K8C t max:10	105 €	1	MGM. 8C
	SM25653	SM25615	BIKT R/L 50-K8C t max:15	265 €	1	

Głowice do frezowania na płytce APKT 1003

Ordering Code	Item Designation		Price	Master insert*
	<i>ST90 APKT 1003.. ISO</i>		<i>EURO</i>	
SM12493	ST90 AP10 D12 W12 L120 Z01	-	46 €	APKT 1003..
SM12172	ST90 AP10 D12 W16 L120 Z01	-	46 €	
SM12189	ST90 AP10 D14 W16 L120 Z01	-	48 €	
SM01729	ST90 AP10 D16 W16 L100 Z02-H 	✓	55 €	
SM12196	ST90 AP10 D16 W16 L120 Z02	-	55 €	
SM12486	ST90 AP10 D16 W16 L120 Z02-H	✓	59 €	
SM12264	ST90 AP10 D16 W16 L150 Z02	-	75 €	
SM27794	ST90 AP10 D16 W16 L150 Z02-H	✓	78 €	
SM12318	ST90 AP10 D16 C16 L200 Z02	-	73 €	
SM38592	ST90 AP10 D16 C16 L200 Z02-H	✓	80 €	
SM38639	ST90 AP10 D17 W16 L150 Z02	-	75 €	
SM38585	ST90 AP10 D17 C16 L200 Z02	-	80 €	
SM12202	ST90 AP10 D18 W16 L120 Z02	-	55 €	
SM12271	ST90 AP10 D18 W16 L150 Z02	-	75 €	
SM38578	ST90 AP10 D18 C16 L200 Z02-H	✓	91 €	
SM12325	ST90 AP10 D18 C16 L200 Z02	-	80 €	
SM01736	ST90 AP10 D20 W20 L100 Z03-H 	✓	61 €	
SM12219	ST90 AP10 D20 W20 L120 Z03	-	61 €	
SM12394	ST90 AP10 D20 W20 L120 Z03-H	✓	66 €	
SM12288	ST90 AP10 D20 W20 L150 Z03	-	77 €	
SM38622	ST90 AP10 D20 W20 L150 Z03-H	✓	80 €	
SM38561	ST90 AP10 D20 C20 L200 Z03-H	✓	106 €	
SM12349	ST90 AP10 D20 C20 L200 Z03	-	91 €	
SM38615	ST90 AP10 D21 W20 L150 Z03	-	77 €	
SM38554	ST90 AP10 D21 C20 L200 Z03	-	105 €	
SM12226	ST90 AP10 D22 W20 L120 Z03	-	61 €	
SM12295	ST90 AP10 D22 W20 L150 Z03	-	77 €	
SM12356	ST90 AP10 D22 C20 L200 Z03	-	96 €	
SM12370	ST90 AP10 D23 W20 L120 Z03	-	63 €	
SM12233	ST90 AP10 D24 W20 L120 Z03	-	63 €	
SM12387	ST90 AP10 D24 W20 L150 Z03	-	84 €	
SM26889	ST90 AP10 D24 C20 L200 Z03	-	100 €	
SM01743	ST90 AP10 D25 W25 L100 Z03-H 	✓	68 €	
SM12240	ST90 AP10 D25 W25 L120 Z03	-	68 €	
SM12417	ST90 AP10 D25 W25 L120 Z03-H	✓	75 €	
SM12332	ST90 AP10 D25 W25 L150 Z03	-	84 €	
SM38608	ST90 AP10 D25 W25 L150 Z03-H	✓	90 €	
SM12363	ST90 AP10 D25 C25 L200 Z03	-	100 €	
SM12479	ST90 AP10 D25 C25 L250 Z03	-	117 €	
SM12509	ST90 AP10 D26 W25 L120 Z03-H	✓	75 €	
SM12516	ST90 AP10 D26 W25 L150 Z03	-	84 €	
SM12523	ST90 AP10 D26 C25 L200 Z03	-	100 €	
SM12165	ST90 AP10 D30 W25 L120 Z04	-	75 €	
SM12455	ST90 AP10 D30 W25 L150 Z04	-	87 €	
SM12400	ST90 AP10 D32 W25 L120 Z04	-	80 €	
SM12257	ST90 AP10 D32 W32 L120 Z04	-	75 €	
SM12424	ST90 AP10 D32 W32 L120 Z04-H	✓	90 €	
SM12431	ST90 AP10 D32 W25 L150 Z04	-	87 €	
SM12448	ST90 AP10 D32 W32 L150 Z04	-	80 €	
SM24113	ST90 AP10 D32 C32 L300 Z04	-	158 €	
SM12301	ST90 AP10 D35 W32 L120 Z05	-	87 €	
SM12158	ST90 AP10 D40 W32 L120 Z05	-	92 €	
SM12462	ST90 AP10 D40 W32 L150 Z05	-	91 €	



Głowice do frezowania na płytce APKT 1003



Ordering Code	Item Designation		Price	Master Insert*
	<i>MT90 APKT 1003.. ISO</i>		EURO	
SM15586	MT90 AP10 D16 M08 L25 Z02-H	✓	85 €	APKT 1003..
SM15593	MT90 AP10 D20 M10 L30 Z03-H	✓	88 €	
SM15609	MT90 AP10 D25 M12 L35 Z03-H	✓	94 €	
SM15616	MT90 AP10 D32 M16 L43 Z04-H	✓	102 €	
SM15623	MT90 AP10 D40 M16 L43 Z05-H	✓	107 €	
SM15630	MT90 AP10 D42 M16 L43 Z05-H	✓	111 €	



Ordering Code	Item Designation		Price	Master Insert*
	<i>TK90 APKT 1003.. ISO</i>		EURO	
SM29309	TK90 AP10 D40 A16 Z05-H	✓	75 €	APKT 1003..
SM13995	TK90 AP10 D40 A16 Z05	-	70 €	
SM29293	TK90 AP10 D50 A22 Z06-H	✓	92 €	
SM14008	TK90 AP10 D50 A22 Z06	-	85 €	
SM29286	TK90 AP10 D63 A22 Z07-H	✓	107 €	
SM14015	TK90 AP10 D63 A22 Z07	-	100 €	
SM29279	TK90 AP10 D80 A27 Z08-H	✓	118 €	
SM14022	TK90 AP10 D80 A27 Z08	-	127 €	
SM29262	TK90 AP10 D100 A32 Z09-H	✓	140 €	
SM14039	TK90 AP10 D100 A32 Z09	-	147 €	
SM13988	TK90 AP10 D125 B40 Z11	-	209 €	

Głowice do frezowania na płytce ZNGX 080606 (XNEX)



Ordering Code	Item Designation		Price	Master Insert*
	<i>TK90 XNEX 0806..</i>		EURO	
SM28524	TK90 XNEX08 D50 A22 Z04-H	✓	108 €	XNEX 0806..
SM28517	TK90 XNEX08 D63 A22 Z05-H	✓	125 €	
SM28500	TK90 XNEX08 D80 A27 Z07-H	✓	148 €	
SM32309	TK90 XNEX08 D100 A32 Z08-H	✓	177 €	
SM32316	TK90 XNEX08 D125 B40 Z10	-	236 €	

Głowice do frezowania na płytce R390-11

Ordering Code	Item Designation	Price	Master Insert*
<i>ST90 R390.0702.. / R390.11T3.. / R390.1704</i>		EURO	
SM58101	ST90 R390.07 D10 W10 L100 Z02-H	101 €	R390-0702..
SM58118	ST90 R390.07 D12 W12 L100 Z02-H	101 €	
SM58125	ST90 R390.07 D14 W12 L100 Z03-H	101 €	
SM58132	ST90 R390.07 D16 W16 L110 Z04-H	101 €	
SM29873	ST90 R390.11 D16 W16 L100 Z02-H	65 €	R390-11T3..
SM13780	ST90 R390.11 D16 W16 L150 Z02	73 €	
SM13797	ST90 R390.11 D16 W16 L150 Z02-H	83 €	
SM13759	ST90 R390.11 D20 W20 L100 Z03-H	68 €	
SM27053	ST90 R390.11 D20 W20 L110 Z03-H	68 €	
SM13803	ST90 R390.11 D20 W20 L150 Z03	78 €	
SM13810	ST90 R390.11 D20 W20 L150 Z03-H	88 €	
SM37885	ST90 R390.11 D25 W25 L100 Z03-H	76 €	
SM13827	ST90 R390.11 D25 W25 L150 Z03	83 €	R390-1704..
SM13858	ST90 R390.11 D25 W25 L150 Z03-H	97 €	
SM13834	ST90 R390.17 D25 W25 L150 Z02	83 €	
SM13865	ST90 R390.17 D25 W25 L150 Z02-H	97 €	
SM13841	ST90 R390.17 D30 W25 L150 Z03	88 €	
SM13872	ST90 R390.17 D30 W25 L150 Z03-H	99 €	

Ordering Code	Item Designation	Price	Master Insert*
<i>MT90 R390.11T3..</i>		EURO	
SM23871	MT90 R390.11 D16 M08 L25 Z02-H	85 €	R390-11T3..
SM23888	MT90 R390.11 D20 M10 L30 Z03-H	90 €	
SM23895	MT90 R390.11 D25 M12 L35 Z03-H	94 €	
SM23918	MT90 R390.11 D32 M16 L43 Z04-H	102 €	

Ordering Code	Item Designation	Price	Master Insert*
<i>TK90 R390.11T3.. / R390.1704.. / R390.1806..</i>		EURO	
SM29156	TK90 R390.11 D40 A16 Z05-H	72 €	R390-11T3..
SM29149	TK90 R390.11 D50 A22 Z06-H	89 €	
SM29132	TK90 R390.11 D63 A22 Z07-H	103 €	
SM29125	TK90 R390.17 D40 A16 Z04-H	68 €	R390-1704..
SM29118	TK90 R390.17 D50 A22 Z05-H	86 €	
SM29101	TK90 R390.17 D63 A22 Z06-H	102 €	
SM29095	TK90 R390.17 D80 A27 Z07-H	117 €	
SM29088	TK90 R390.17 D100 A32 Z08-H	141 €	
SM14305	TK90 R390.17 D125 B40 Z09	209 €	R390-1806..
SM50204	TK90 R390.18 D50 A22 Z05-H	121 €	
SM50211	TK90 R390.18 D63 A22 Z06-H	132 €	
SM50228	TK90 R390.18 D80 A27 Z07-H	149 €	
SM50235	TK90 R390.18 D100 A32 Z08-H	158 €	
SM54097	TK90 R390.18 D125 B40 Z09	237 €	
SM54103	TK90 R390.18 D160 C40 Z12	350 €	

Głowice do frezowania na płytki LNMU 0603 (BLMP)



Ordering Code	Item Designation		Price	Master Insert ⁺
	<i>HST BLMP</i> 0603.. / 0904.. / 1105..		EURO	
SM34921	HST BL06 D16 W16 L120 Z02-H		94 €	BLMP 0603..
SM00685	HST BL06 D17 W16 L150 Z02-H		103 €	
SM34938	HST BL06 D20 W20 L150 Z03-H		101 €	
SM34983	HST BL06 D20 C20 L200 Z03	-	115 €	
SM00692	HST BL06 D21 W20 L150 Z03-H		111 €	
SM34945	HST BL06 D25 W25 L150 Z04-H		122 €	
SM34976	HST BL06 D25 C25 L200 Z04	-	137 €	
SM00708	HST BL06 D26 W25 L150 Z04-H		134 €	
SM34952	HST BL06 D32 W32 L150 Z05-H		130 €	
SM34990	HST BL06 D32 C32 L200 Z05	-	144 €	
SM60807	HST BL06 D35 W32 L150 Z05-H		132 €	



Ordering Code	Item Designation		Price	Master Insert ⁺
	<i>MHT BLMP</i> 0603 / 0904		EURO	
SM36673	MHT BL06 D16 M08 L25 Z02-H		87 €	BLMP 0603..
SM36697	MHT BL06 D20 M10 L30 Z03-H		103 €	
SM36710	MHT BL06 D25 M12 L35 Z04-H		106 €	
SM36727	MHT BL06 D32 M16 L43 Z05-H		110 €	
SM47730	MHT BL06 D35 M16 L43 Z05-H		110 €	
SM00838	MHT BL06 D40 M16 L43 Z06-H		132 €	
SM56633	MHT BL06 D42 M16 L43 Z06-H		134 €	BLMP 0904..
SM58897	MHT BL09 D25 M12 L35 Z03-H		111 €	
SM58903	MHT BL09 D32 M16 L43 Z04-H		116 €	
SM58910	MHT BL09 D35 M16 L43 Z04-H		116 €	
SM58927	MHT BL09 D40 M16 L43 Z05-H		132 €	



Ordering Code	Item Designation		Price	Master Insert ⁺
	<i>HTK BLMP</i> 0603.. / 0904.. / 1105..		EURO	
SM38967	HTK BL06 D40 A16 Z06-H		106 €	BLMP 0603..
SM33177	HTK BL06 D50 A22 Z07-H		128 €	
SM28050	HTK BL09 D40 A16 Z05-H		94 €	
SM28043	HTK BL09 D50 A22 Z06-H		114 €	BLMP 0904..
SM22607	HTK BL09 D63 A22 Z07-H		128 €	
SM54561	HTK BL11 D40 A16 Z04-H		94 €	BLMP 1105..
SM54578	HTK BL11 D50 A22 Z05-H		114 €	
SM54585	HTK BL11 D52 A22 Z05-H		129 €	
SM54592	HTK BL11 D63 A22 Z06-H		140 €	
SM54608	HTK BL11 D66 A27 Z06-H		157 €	

Wytaczadła do obróbki zgrubnej



Ordering Code	Item Designation	Price	Master Insert
	<i>SBT-CC..0602.. / 09T3.. / 1204.. ADJUSTABLE BORING BARS</i>	<i>EURO</i>	
SM15906	SBT-CC06 D20-24 I50 W16 L100	198 €	CC.. 0602..
SM15937	SBT-CC06 D20-24 I100 W16 L150	209 €	
SM16019	SBT-CC06 D20-24 I150 W16 L200	255 €	
SM15913	SBT-CC06 D24-29 I50 W20 L100	206 €	
SM23598	SBT-CC06 D24-29 I100 W20 L150	209 €	
SM16026	SBT-CC06 D24-29 I180 W20 L230	255 €	
SM15920	SBT-CC09 D29-39 I55 W20 L105	206 €	CC.. 09T3..
SM15968	SBT-CC09 D29-39 I105 W20 L155	225 €	
SM15890	SBT-CC09 D29-39 I175 W20 L230	270 €	
SM15944	SBT-CC09 D39-49 I65 W25 L120	206 €	
SM15975	SBT-CC09 D39-49 I115 W25 L170	227 €	
SM16057	SBT-CC09 D39-49 I200 W25 L250	277 €	
SM15951	SBT-CC09 D49-60 I66 W32 L126	213 €	
SM15883	SBT-CC09 D49-60 I116 W32 L176	241 €	
SM16071	SBT-CC09 D49-60 I200 W32 L260	284 €	
SM15982	SBT-CC12 D59-79 I85 W32 L145	234 €	
SM16002	SBT-CC12 D59-79 I135 W32 L195	241 €	
SM16088	SBT-CC12 D59-79 I220 W32 L280	301 €	
SM15999	SBT-CC12 D69-89 I85 W32 L145	241 €	
SM16033	SBT-CC12 D69-89 I135 W32 L195	262 €	
SM39582	SBT-CC12 D69-89 I220 W32 L290	319 €	
SM16095	SBT-CC12 D69-89 I220 W40 L290	319 €	
SM16040	SBT-CC12 D89-130 I105 W32 L175	262 €	
SM16064	SBT-CC12 D89-130 I165 W32 L225	277 €	

Wiertła 3D na płytki SPMG

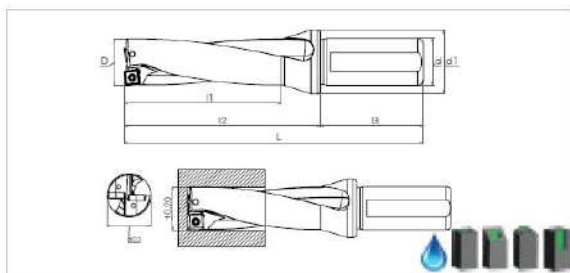

Ordering Code	Item Designation	POWER SERIES	Dimensions (mm)							Price	Master Insert*
			D	d	d1	L	l1	l2	l3		
SDUM Dx3 - SPMG 050204 / 060204 / 07T308 U-DRILL										EURO	
SM18846	SDUM 12.5XD3 SPMG 050204	✓	12.5	20	25	107	37	57	50	140 €	SPMG 050204
SM18853	SDUM 13XD3 SPMG 050204	✓	13	20	25	107	39	57	50	140 €	
SM18860	SDUM 13.5XD3 SPMG 050204	✓	13.5	20	25	110	40.5	60	50	140 €	
SM18877	SDUM 14XD3 SPMG 050204	✓	14	20	25	110	42	60	50	140 €	
SM18884	SDUM 14.5XD3 SPMG 050204	✓	14.5	20	25	113	43.5	63	50	140 €	
SM18891	SDUM 15XD3 SPMG 050204	✓	15	20	25	113	45	63	50	140 €	SPMG 060204
SM18907	SDUM 15.5XD3 SPMG 060204	✓	15.5	20	25	118	46.5	68	50	140 €	
SM18013	SDUM 16XD3 SPMG 060204	✓	16	25	34	124	48	68	56	140 €	
SM18167	SDUM 16.5XD3 SPMG 060204	✓	16.5	25	34	127	49.5	71	56	140 €	
SM18020	SDUM 17XD3 SPMG 060204	✓	17	25	34	127	51	71	56	140 €	
SM18174	SDUM 17.5XD3 SPMG 060204	✓	17.5	25	34	131	52.5	75	56	140 €	
SM18037	SDUM 18XD3 SPMG 060204	✓	18	25	34	131	54	75	56	140 €	
SM18181	SDUM 18.5XD3 SPMG 060204	✓	18.5	25	34	134	55.5	78	56	140 €	
SM18044	SDUM 19XD3 SPMG 060204	✓	19	25	34	134	57	78	56	140 €	
SM18198	SDUM 19.5XD3 SPMG 060204	✓	19.5	25	34	139	58.5	83	56	140 €	
SM18617	SDUM 20XD3 SPMG 060204	✓	20	25	34	139	60	83	56	144 €	SPMG 07T308
SM18921	SDUM 20.5XD3 SPMG 060204	✓	20.5	25	34	142	61.5	88	56	144 €	
SM18624	SDUM 21XD3 SPMG 060204	✓	21	25	34	142	63	88	56	144 €	
SM18914	SDUM 21.5XD3 SPMG 060204	✓	21.5	25	34	145	64.5	89	56	144 €	
SM18655	SDUM 22XD3 SPMG 07T308	✓	22	25	34	145	66	89	56	144 €	
SM18945	SDUM 22.5XD3 SPMG 07T308	✓	22.5	25	34	150	67.5	94	56	144 €	
SM18648	SDUM 23XD3 SPMG 07T308	✓	23	25	34	150	69	94	56	144 €	
SM18938	SDUM 23.5XD3 SPMG 07T308	✓	23.5	25	34	154	70.5	98	56	144 €	
SM18631	SDUM 24XD3 SPMG 07T308	✓	24	25	34	154	72	98	56	144 €	
SM18495	SDUM 24.5XD3 SPMG 07T308	✓	24.5	25	34	158	73.5	102	56	144 €	
SM18662	SDUM 25XD3 SPMG 07T308	✓	25	25	34	158	75	102	56	150 €	
SM18051	SDUM 25.5XD3 SPMG 07T308	✓	25.5	25	34	161	76.5	105	56	150 €	
SM18686	SDUM 26XD3 SPMG 07T308	✓	26	25	34	161	78	105	56	150 €	
SM18068	SDUM 26.5XD3 SPMG 07T308	✓	26.5	25	34	164	79.5	108	56	150 €	
SM18679	SDUM 27XD3 SPMG 07T308	✓	27	25	34	164	81	108	56	150 €	
SM18075	SDUM 27.5XD3 SPMG 07T308	✓	27.5	25	34	168	82.5	112	56	150 €	

Ordering Code	Item Designation	Dimensions (mm)								Price	Master Insert*
	<i>SDUM Dx3 - SPMG 090408 / 110408 / 140512 U-DRILL</i>	POWER SERIES	<i>D</i>	<i>d</i>	<i>d1</i>	<i>L</i>	<i>l1</i>	<i>l2</i>	<i>l3</i>	<i>EURO</i>	
SM18709	SDUM 28XD3 SPMG 090408	✓	28	25	34	168	84	112	56	150 €	SPMG 090408
SM18822	SDUM 28.5XD3 SPMG 090408	✓	28.5	25	34	171	85.5	115	56	150 €	
SM18693	SDUM 29XD3 SPMG 090408	✓	29	25	34	171	87	115	56	150 €	
SM18839	SDUM 29.5XD3 SPMG 090408	✓	29.5	25	34	177	88.5	111	56	150 €	
SM19041	SDUM 30XD3 SPMG 090408	✓	30	32	44	171	90	111	60	155 €	
SM19133	SDUM 31XD3 SPMG 090408	✓	31	32	44	175	93	115	60	155 €	
SM19027	SDUM 32XD3 SPMG 090408	✓	32	32	44	178	96	118	60	155 €	
SM19034	SDUM 33XD3 SPMG 090408	✓	33	32	44	182	99	122	60	155 €	
SM18952	SDUM 34XD3 SPMG 110408	✓	34	32	44	185	102	125	60	155 €	SPMG 110408
SM18969	SDUM 35XD3 SPMG 110408	✓	35	32	44	189	105	129	60	155 €	
SM18976	SDUM 36XD3 SPMG 110408	✓	36	32	44	193	108	133	60	155 €	
SM18983	SDUM 37XD3 SPMG 110408	✓	37	32	44	197	111	136	60	155 €	
SM18990	SDUM 38XD3 SPMG 110408	✓	38	32	44	201	114	141	60	155 €	
SM19003	SDUM 39XD3 SPMG 110408	✓	39	32	44	204	117	144	60	155 €	
SM19010	SDUM 40XD3 SPMG 110408	✓	40	32	44	208	120	148	60	155 €	
SM19096	SDUM 41XD3 SPMG 110408	✓	41	32	44	212	123	152	60	171 €	
SM19102	SDUM 42XD3 SPMG 140512	✓	42	32	44	215	126	155	60	171 €	SPMG 140512
SM19140	SDUM 43XD3 SPMG 140512	✓	43	32	44	219	129	158	60	171 €	
SM19157	SDUM 44XD3 SPMG 140512	✓	44	32	44	222	132	162	60	171 €	
SM19164	SDUM 45XD3 SPMG 140512	✓	45	40	60	237	135	167	70	171 €	
SM19171	SDUM 46XD3 SPMG 140512	✓	46	40	60	241	138	171	70	176 €	
SM19188	SDUM 47XD3 SPMG 140512	✓	47	40	60	244	141	174	70	185 €	
SM19195	SDUM 48XD3 SPMG 140512	✓	48	40	60	248	144	178	70	193 €	
SM19201	SDUM 49XD3 SPMG 140512	✓	49	40	60	251	147	181	70	199 €	
SM19218	SDUM 50XD3 SPMG 140512	✓	50	40	60	255	150	185	70	207 €	
SM19225	SDUM 51XD3 SPMG 140512	✓	51	40	60	258	153	188	70	220 €	
SM19454	SDUM 52XD3 SPMG 140512	✓	52	40	60	261	156	191	70	225 €	
SM19355	SDUM 53XD3 SPMG 140512	✓	53	40	60	264	159	194	70	233 €	
SM19386	SDUM 54XD3 SPMG 140512	✓	54	40	60	267	162	197	70	254 €	

Wiertła 4D na płytki SPMG

Ordering Code	Item Designation		Dimensions (mm)							Price	Master Insert*
	<i>SDUM Dx4 - SPMG 050204 / 060204 / 07T308 U-DRILL</i>	POWER SERIES	<i>D</i>	<i>d</i>	<i>d1</i>	<i>L</i>	<i>l1</i>	<i>l2</i>	<i>l3</i>	<i>EURO</i>	
SM25370	SDUM 12.5XD4 SPMG 050204	✓	12.5	20	25	120	52	70	50	175 €	SPMG 050204
SM18204	SDUM 13XD4 SPMG 050204	✓	13	20	25	120	52	70	50	175 €	
SM19744	SDUM 13.5XD4 SPMG 050204	✓	13.5	20	25	120	52	70	50	175 €	
SM18211	SDUM 14XD4 SPMG 050204	✓	14	20	25	124	56	73	50	175 €	
SM19751	SDUM 14.5XD4 SPMG 050204	✓	14.5	20	25	124	56	78	50	175 €	
SM18228	SDUM 15XD4 SPMG 050204	✓	15	20	25	128	60	78	50	175 €	
SM19768	SDUM 15.5XD4 SPMG 060204	✓	15.5	20	25	128	60	85	50	175 €	SPMG 060204
SM18235	SDUM 16XD4 SPMG 060204	✓	16	25	34	140	64	84	56	177 €	
SM19720	SDUM 16.5XD4 SPMG 060204	✓	16.5	25	34	144	66	84	56	177 €	
SM18242	SDUM 17XD4 SPMG 060204	✓	17	25	34	144	68	88	56	177 €	
SM19775	SDUM 17.5XD4 SPMG 060204	✓	17.5	25	34	149	70	88	56	177 €	
SM18259	SDUM 18XD4 SPMG 060204	✓	18	25	34	149	72	93	56	177 €	
SM19782	SDUM 18.5XD4 SPMG 060204	✓	18.5	25	34	153	74	93	56	177 €	
SM18266	SDUM 19XD4 SPMG 060204	✓	19	25	34	153	76	97	56	177 €	
SM19799	SDUM 19.5XD4 SPMG 060204	✓	19.5	25	34	159	78	97	56	177 €	
SM18273	SDUM 20XD4 SPMG 060204	✓	20	25	34	159	80	103	56	177 €	
SM19805	SDUM 20.5XD4 SPMG 060204	✓	20.5	25	34	163	82	103	56	177 €	
SM18280	SDUM 21XD4 SPMG 060204	✓	21	25	34	163	84	107	56	185 €	
SM19812	SDUM 21.5XD4 SPMG 060204	✓	21.5	25	34	167	86	107	56	185 €	
SM18297	SDUM 22XD4 SPMG 07T308	✓	22	25	34	167	88	111	56	185 €	
SM19829	SDUM 22.5XD4 SPMG 07T308	✓	22.5	25	34	173	90	111	56	185 €	
SM18303	SDUM 23XD4 SPMG 07T308	✓	23	25	34	173	92	117	56	185 €	
SM19836	SDUM 23.5XD4 SPMG 07T308	✓	23.5	25	34	178	94	117	56	185 €	
SM18310	SDUM 24XD4 SPMG 07T308	✓	24	25	34	178	96	122	56	185 €	
SM19843	SDUM 24.5XD4 SPMG 07T308	✓	24.5	25	34	183	98	122	56	185 €	
SM18327	SDUM 25XD4 SPMG 07T308	✓	25	25	34	183	100	127	56	185 €	
SM19737	SDUM 25.5XD4 SPMG 07T308	✓	25.5	25	34	187	102	127	56	185 €	
SM18334	SDUM 26XD4 SPMG 07T308	✓	26	25	34	187	104	131	56	206 €	
SM19850	SDUM 26.5XD4 SPMG 07T308	✓	26.5	25	34	191	106	131	56	206 €	
SM18341	SDUM 27XD4 SPMG 07T308	✓	27	25	34	191	108	135	56	206 €	
SM19867	SDUM 27.5XD4 SPMG 07T308	✓	27.5	25	34	196	110	135	56	206 €	

Wiertła 4D na płytki SPMG

Ordering Code	Item Designation	Dimensions (mm)								Price	Master Insert*
	<i>SDUM Dx4 - SPMG</i> <i>090408 / 110408 / 140512</i> <i>U-DRILL</i>	POWER SERIES	<i>D</i>	<i>d</i>	<i>d1</i>	<i>L</i>	<i>l1</i>	<i>l2</i>	<i>l3</i>	<i>EURO</i>	
SMI8358	SDUM 28XD4 SPMG 090408	✓	28	25	34	196	112	140	56	206 €	SPMG 090408
SMI9874	SDUM 28.5XD4 SPMG 090408	✓	28.5	25	34	200	114	140	56	206 €	
SMI8372	SDUM 29XD4 SPMG 090408	✓	29	25	34	200	116	144	56	206 €	
SMI9881	SDUM 29.5XD4 SPMG 090408	✓	29.5	25	34	202	118	144	56	206 €	
SMI8365	SDUM 30XD4 SPMG 090408	✓	30	32	44	201	120	141	60	220 €	
SMI8389	SDUM 31XD4 SPMG 090408	✓	31	32	44	206	124	145	60	220 €	
SMI8396	SDUM 32XD4 SPMG 090408	✓	32	32	44	210	128	149	60	220 €	
SMI8402	SDUM 33XD4 SPMG 090408	✓	33	32	44	215	132	154	60	220 €	
SMI25417	SDUM 33.5XD4 SPMG 090408	✓	33.5	32	44	219	134	158	60	220 €	
SMI8419	SDUM 34XD4 SPMG 110408	✓	34	32	44	219	136	158	60	220 €	
SMI8426	SDUM 35XD4 SPMG 110408	✓	35	32	44	224	140	166	60	220 €	
SMI8433	SDUM 36XD4 SPMG 110408	✓	36	32	44	229	144	169	60	220 €	
SMI8440	SDUM 37XD4 SPMG 110408	✓	37	32	44	234	148	172	60	233 €	
SMI8457	SDUM 38XD4 SPMG 110408	✓	38	32	44	239	152	178	60	233 €	
SM20948	SDUM 38.5XD4 SPMG 110408	✓	38.5	32	44	243	154	181	60	233 €	
SMI8464	SDUM 39XD4 SPMG 110408	✓	39	32	44	243	156	181	60	233 €	
SMI8471	SDUM 40XD4 SPMG 110408	✓	40	32	44	248	160	188	60	233 €	
SMI9119	SDUM 41XD4 SPMG 110408	✓	41	32	44	253	164	191	60	239 €	SPMG 140512
SMI9126	SDUM 42XD4 SPMG 140512	✓	42	32	44	257	168	195	60	239 €	
SMI9362	SDUM 43XD4 SPMG 140512	✓	43	32	44	262	172	197	60	239 €	
SMI9379	SDUM 44XD4 SPMG 140512	✓	44	32	44	266	176	200	60	239 €	

Wiertła 5D na płytki SPMG

Ordering Code	Item Designation	Dimensions (mm)								Price	Master Insert*
	<i>SDUM Dx5 - SPMG</i> <i>050204 / 060204 / 07T308 /</i> <i>090408</i> <i>U-DRILL</i>	POWER SERIES	<i>D</i>	<i>d</i>	<i>d1</i>	<i>L</i>	<i>l1</i>	<i>l2</i>	<i>l3</i>	<i>EURO</i>	
SMI9676	SDUM 13XD5 SPMG 050204	✓	13	20	25	130	65	80	50	177 €	SPMG 050204
SMI9669	SDUM 14XD5 SPMG 050204	✓	14	20	25	135	70	85	50	177 €	
SMI8006	SDUM 15XD5 SPMG 050204	✓	15	20	25	140	75	90	50	177 €	
SMI9348	SDUM 16XD5 SPMG 060204	✓	16	25	34	155	80	100	56	208 €	SPMG 060204
SMI9478	SDUM 17XD5 SPMG 060204	✓	17	25	34	160	85	105	56	208 €	
SMI9485	SDUM 18XD5 SPMG 060204	✓	18	25	34	165	90	111	56	208 €	
SMI9492	SDUM 19XD5 SPMG 060204	✓	19	25	34	170	95	116	56	208 €	
SMI9508	SDUM 20XD5 SPMG 060204	✓	20	25	34	175	100	120	56	220 €	
SMI9515	SDUM 21XD5 SPMG 060204	✓	21	25	34	180	105	124	56	220 €	
SMI9522	SDUM 22XD5 SPMG 07T308	✓	22	25	34	185	110	129	56	220 €	SPMG 07T308
SMI9539	SDUM 23XD5 SPMG 07T308	✓	23	25	34	190	115	135	56	233 €	
SMI9546	SDUM 24XD5 SPMG 07T308	✓	24	25	34	195	120	140	56	233 €	
SMI9553	SDUM 25XD5 SPMG 07T308	✓	25	25	34	200	125	144	56	233 €	
SMI9560	SDUM 26XD5 SPMG 07T308	✓	26	25	34	205	130	149	56	233 €	
SMI9577	SDUM 27XD5 SPMG 07T308	✓	27	25	34	210	135	155	56	233 €	
SMI9584	SDUM 28XD5 SPMG 090408	✓	28	25	34	215	140	160	56	246 €	SPMG 090408
SMI9706	SDUM 29XD5 SPMG 090408	✓	29	25	34	220	145	165	56	246 €	