

SWISS-TYPE LATHES MANURHIN K'MX

PRODUCTION PROGRAM



TAJMAC – ZPS



MANURHIN K'MX

K'MX 413

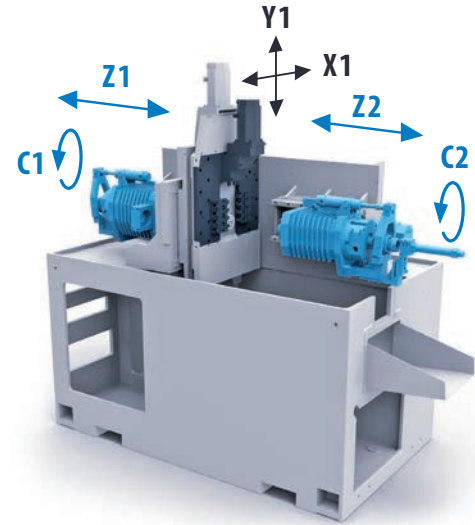
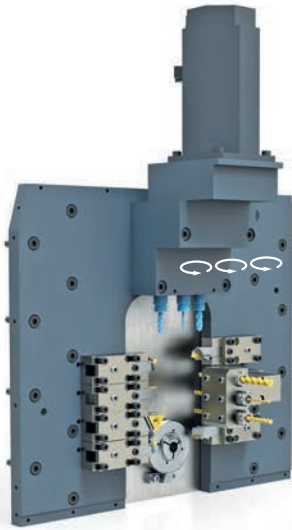

THE MANURHIN K'MX 413 is dedicated to run small parts from $\varnothing 3$ (2)-16 mm (over $\varnothing 13$ mm, preparation of bars is necessary in standard, as an option it can be used with full $\varnothing 16$ mm bars without preparation). Counter spindle, powered tools are included in the basic machine as well as the barloader. With 2 electrospindles, 3 powered tools, C-axis, and up to 12 fixed tools, the K'MX 413 is also able to run complex parts. With this machine, we want to offer an economical, reliable and easy solution. Four linear axes (X1, Y1, Z1, Z2), two rotary axes (C1, C2).

Specifications

Max. diameter of bar stock	$\varnothing 13$ (16)
Spindle bore	$\varnothing 18$ (19)
Spindle power 100 % / 30 min. - main	3.7/5.5 kW
Spindle power 100 % / 30 min. - counter	2.2/3.7 kW
Spindle max. speed - main	12,000 rpm
Spindle max. speed - counter	12,000 rpm
Spindle stroke	130 mm
Number of CNC axes	4+2
Programming channels	2
Tools in cut at the same time max	2
Live tools power	1 kW

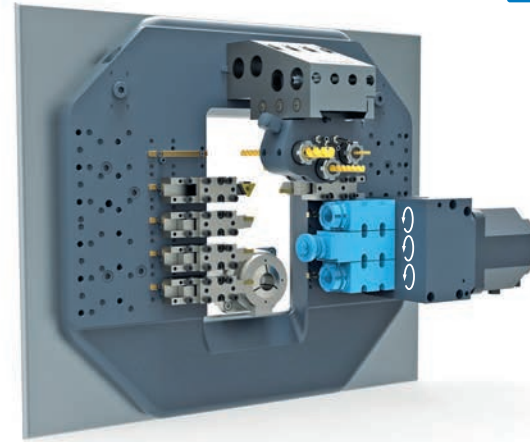
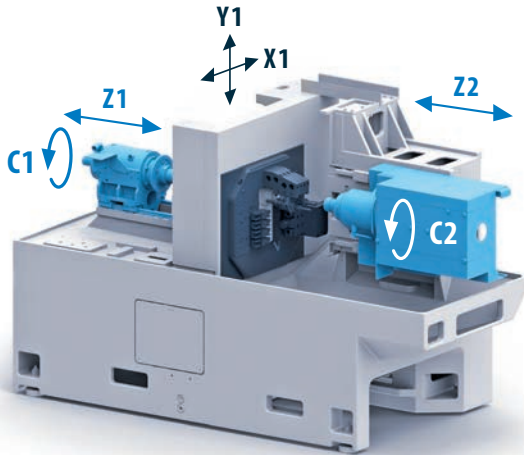

Specifications

Max. diameter of bar stock	∅ 32 (36)
Spindle bore	∅ 37
Spindle power 100 % / 25 % - main	5.5 / 7.5 kW
Spindle power 100 % / 30 min. - counter	3.7 / 5.5 kW
Spindle max. speed - main	10,000 rpm
Spindle max. speed - counter	10,000 rpm
Spindle stroke	410 mm
Number of CNC axes	4+2
Programming channels	2
Tools in cut at the same time max	2
Live tools power	2.3 kW

THE MANURHIN K'MX 432 is designed for productive machining of parts for bars with a maximum diameter of 32 mm. With a spindle bore diameter of 37 mm, no modification of the end of the bar for the bar feeder collet is needed. The machine comes standard with two electrospindles, each with a maximum speed of 10,000 rpm and with a rotary guide bush, synchronized by pulleys and belts from the main spindle. Four linear axes (X1, Y1, Z1, Z2), two rotary axes (C1, C2). The machine is very strong when milling, with torque up to 32 Nm!



K'MX 532 TREND

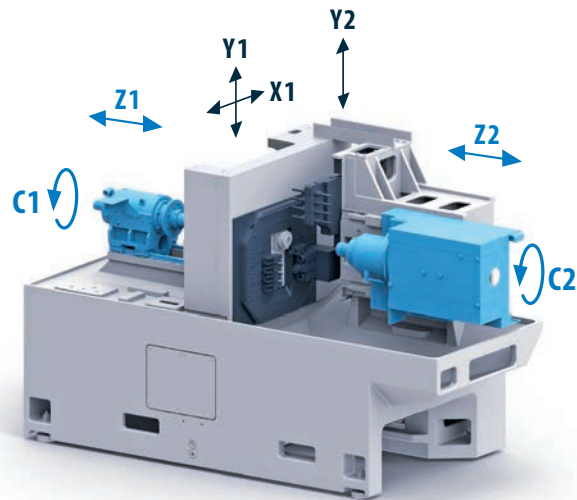
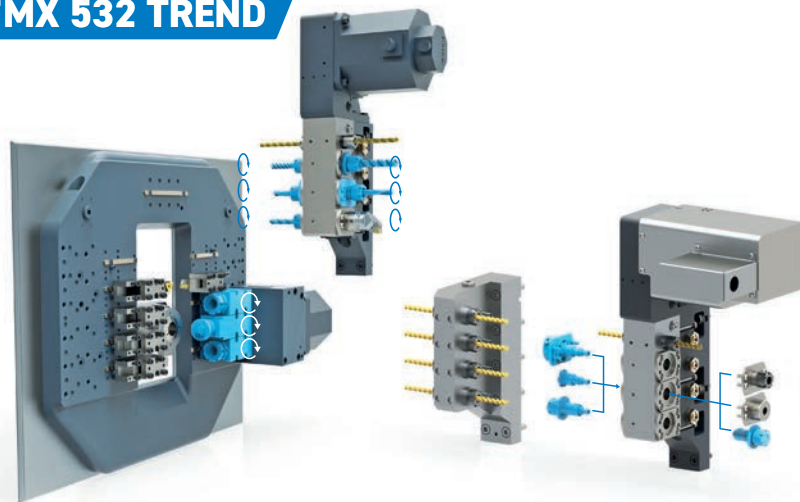

THE MANURHIN K'MX 532 TREND is designed for productive machining of parts for bars with a maximum diameter of 32 mm. With a spindle bore diameter of 37 mm, no modification of the end of the bar for bar feeder collet is needed. The machine comes standard with two electrospindles, each with a maximum speed of 10,000 rpm and with a rotary guide bush, synchronized by pulleys and belts from the main spindle. Five linear axes (X1, Y1, Y2, Z1, Z2) two rotary axes (C1, C2).

The machine is very strong when milling with torque up to 32 Nm!

Specifications

Max. diameter of bar stock	Ø 32 (36)
Spindle bore	Ø 37
Spindle power 100 % / 25 % - main	5.5 / 7.5 kW
Spindle power 100 % / 30 min. - counter	3.7 / 5.5 kW
Spindle max. speed - main	10,000 rpm
Spindle max. speed - counter	10,000 rpm
Spindle stroke	410 mm
Number of CNC axes	5+2
Programming channels	2
Tools in cut at the same time max	2
Live tools power	2.3 kW

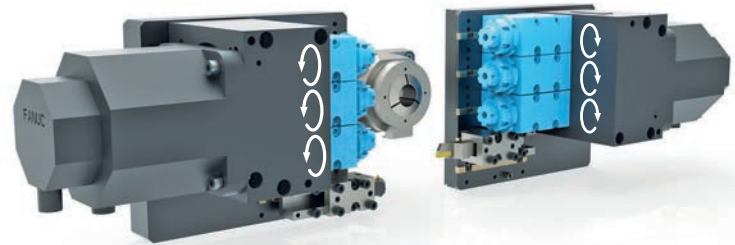
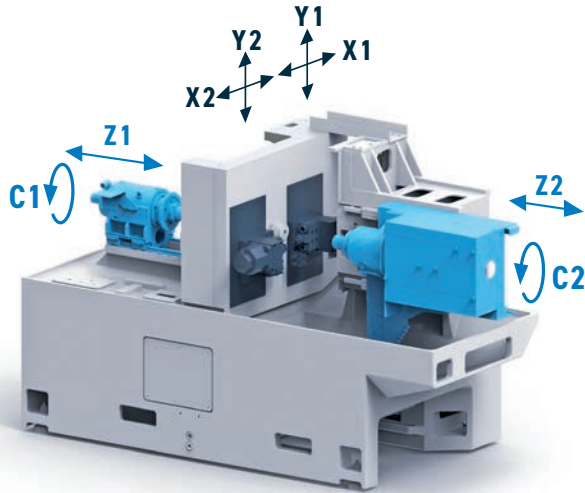

Specifications

Max. diameter of bar stock	∅ 32 (36)
Spindle bore	∅ 37
Spindle power 100 % / 25 % - main	15 / 25 kW
Spindle power 100 % / 30 min. - counter	3.7 / 5.5 kW
Spindle max. speed - main	8,000 rpm
Spindle max. speed - counter	8,000 rpm
Spindle stroke	410 mm
Number of CNC axes	6+2
Programming channels	2
Tools in cut at the same time max	2
Live tools power	2.3 kW

THE MANURHIN K'MX 632 DUO is designed for productive machining of parts for bars with a maximum diameter of 32 mm. With a spindle bore diameter of 37 mm, no modification of the end of the bar for bar feeder collet is needed. The machine comes standard with two electrospindles, each with a maximum speed of 10,000 rpm and with a rotary guide bush synchronized by pulleys and belts from the main spindle. Six linear CNC axes (X1, X2, Y1, Y2, Z1, Z2) and two rotary axes (C1, C2).

The machine is very strong when milling, with torque up to 32 Nm! Another big advantage of this model is possibility of parallel turning or milling with two tools at the same time.



K'MX 732 EVO

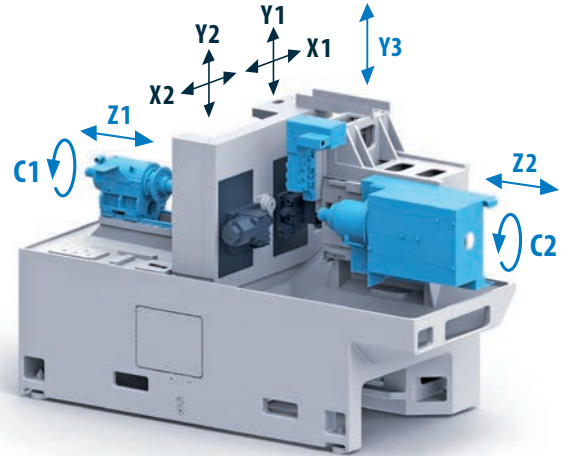
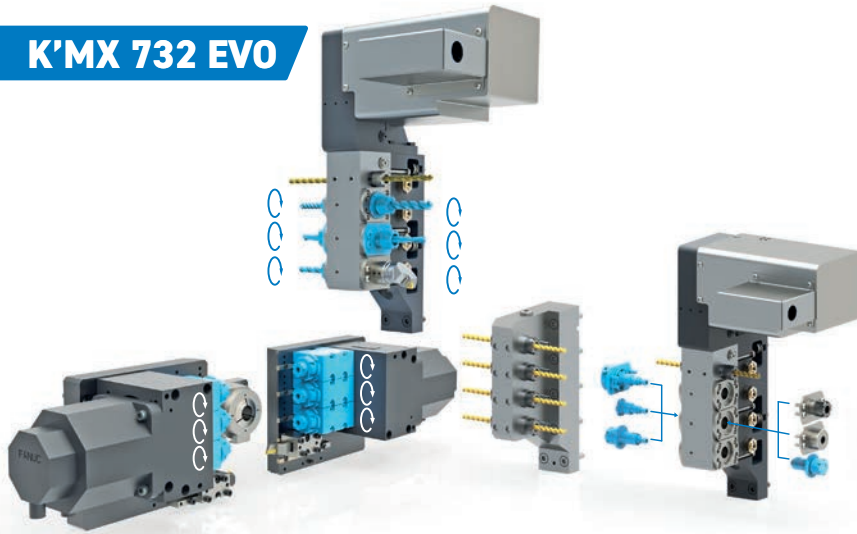

THE MANURHIN K'MX 732 EVO is designed for productive machining of parts for bars with a maximum diameter of 32 mm. The machine comes standard with two electrospindles and with a rotary guide bush synchronized by pulleys and belts from the main spindle. Seven linear CNC axes (X1, X2, Y1, Y2, Y3, Z1, Z2) and two rotary axes (C1, C2) enable the machine to produce parts ranging from very simple to extremely complex. The construction solution and very strong spindle motor enables the use of up to 3 tools at the same time. The machine is very strong when milling, with torque up to 32 Nm!

Specifications

Max. diameter of bar stock	∅ 32 (36)
Spindle bore	∅ 37
Spindle power 100 %/25 % - main	15/25 kW
Spindle power 100 %/30 min. - counter	3.7/5.5 kW
Spindle max. speed - main	8,000 rpm
Spindle max. speed - counter	10,000 rpm
Spindle stroke	410 mm
Number of CNC axes	7+2
Programming channels	2
Tools in cut at the same time max	3
Live tools power	2.3 kW

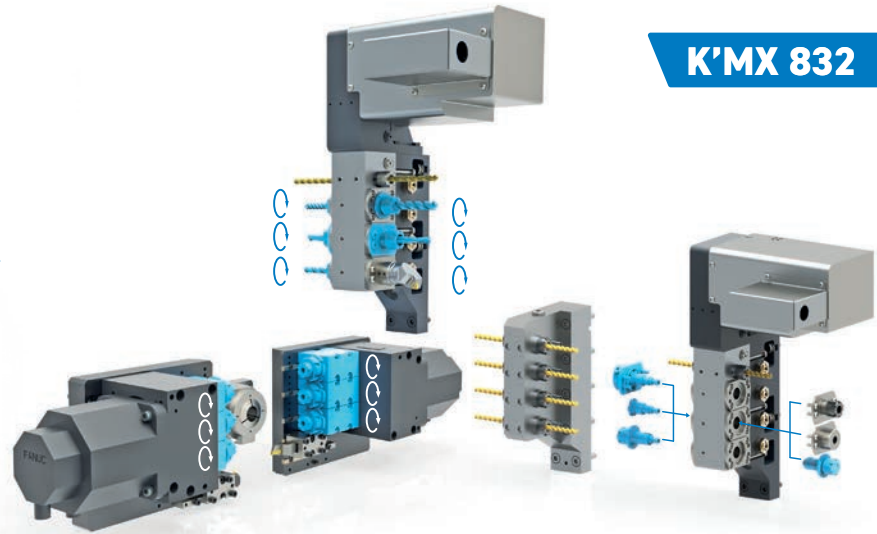
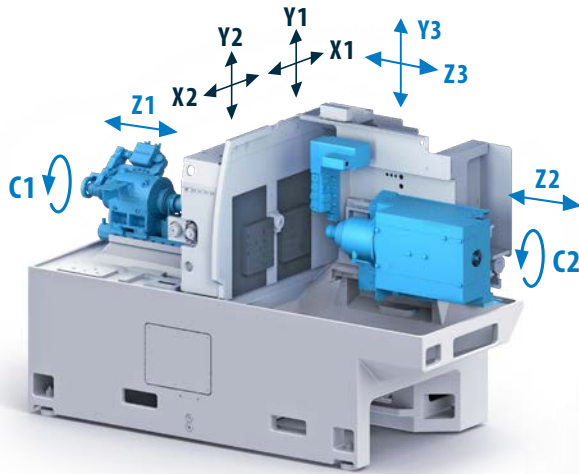

Specifications

Max. diameter of bar stock	∅ 32 (36)
Spindle bore	∅ 37
Spindle power 100 % / 25 % - main	15 / 25 kW
Spindle power 100 % / 30 min. - counter	3.7 / 5.5 kW
Spindle max. speed - main	8,000 rpm
Spindle max. speed - counter	10,000 rpm
Spindle stroke	410 mm
Number of CNC axes	8+2
Programming channels	3
Tools in cut at the same time max	4
Live tools power	2.3 kW

MANURHIN K'MX 832 832 is designed for productive machining of parts from bar material with a maximum diameter of 32 mm. The machine is equipped as standard with two electrospindles and a rotating guide bush synchronized with pulleys and a belt with a main spindle. Eight linear CNC axes (X1, X2, Y1, Y2, Y3, Z1, Z2, Z3), two rotary axes (C1, C2) allow you to machine both simple parts and complex parts with high productivity. The design solution allows the use of up to 4 tools in the cut at the same time. Also available without guide bush. **Very powerful primary spindle motor!!!** The machine is very strong when milling, the tool works with a torque of up to 32 Nm.



K'MX 816 CLEVER

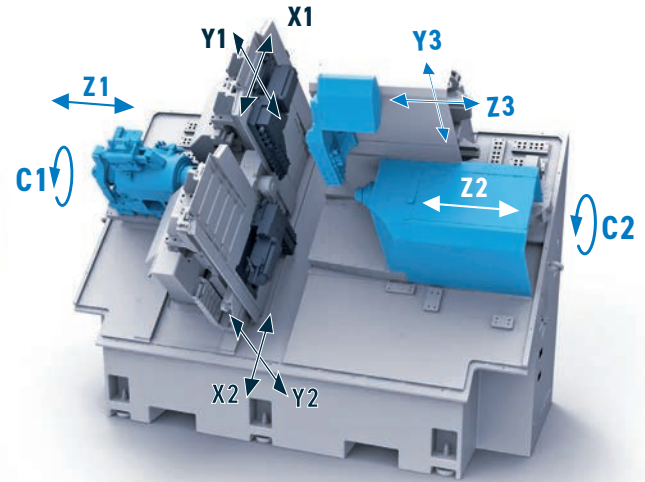
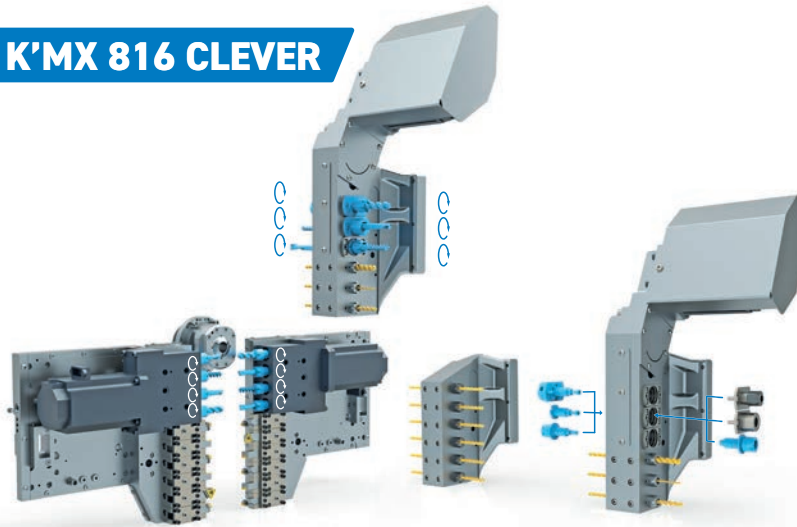

THE MANURHIN K'MX 816 CLEVER is designed for the productive machining of parts for bars of a maximum diameter of either 16 mm or 20 mm. The machine comes standard with two electrospindles and a rotary guide bush that is synchronized by pulleys and belts from the main spindle. Eight linear CNC axes (X1, X2, Y1, Y2, Y3, Z1, Z2, Z3) and two rotary axes (C1, C2) enable the machine to produce parts ranging in complexity. **The construction solution enables the use of 4 tools at the same time.**

Specifications

Max. diameter of bar stock	Ø 16 (20)
Spindle bore	Ø 21 (23)
Spindle power 100 %/30 min. - main	3.7/5.5 kW
Spindle power 100 %/30 min. - counter	3.7/5.5 kW
Spindle max. speed - main	12,000 rpm
Spindle max. speed - counter	12,000 rpm
Spindle stroke Z1	220 mm
Number of CNC axes	8+2
Programming channels	3
Tools in cut at the same time max	4
Live tools power	1 kW

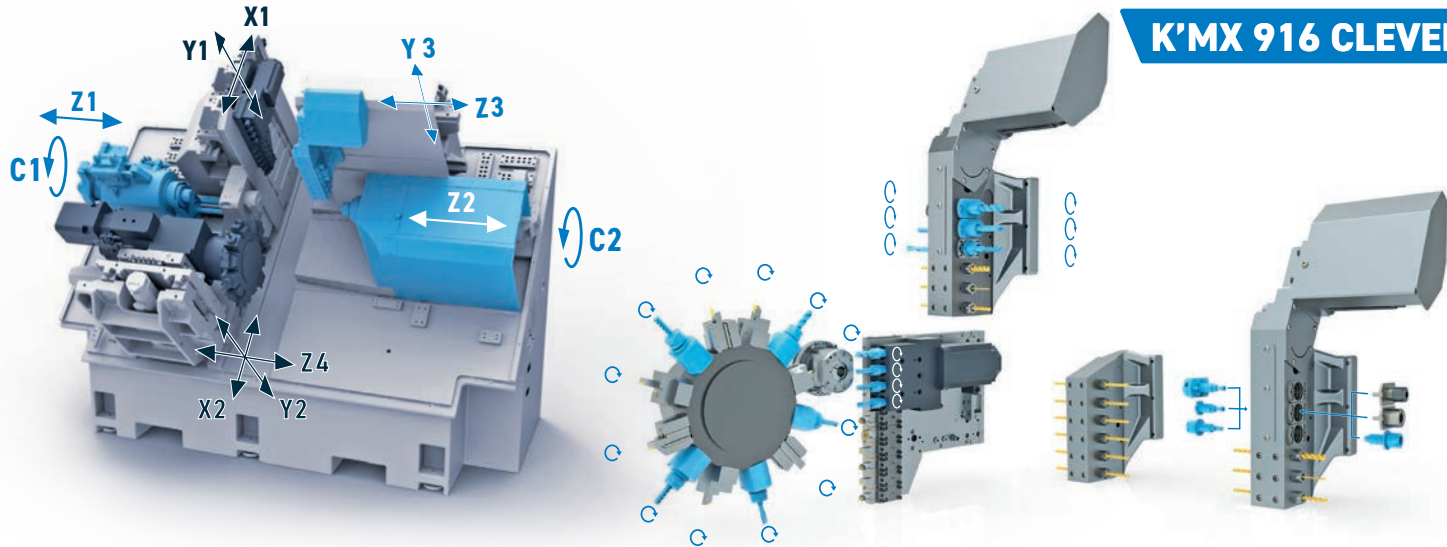

Specifications

Max. diameter of bar stock	∅ 16 (20)
Spindle bore	∅ 21 (23)
Spindle power 100 %/30 min. - main	3.7/5.5 kW
Spindle power 100 %/30 min. - counter	3.7/5.5 kW
Spindle max. speed - main	12,000 rpm
Spindle max. speed - counter	12,000 rpm
Spindle stroke Z1	220 mm
Turret stroke Z4	65 mm
Number of CNC axes	9+2
Programming channels	4
Tools in cut at the same time max	4
Live tools power	2.3 kW

THE MANURHIN K'MX 916 CLEVER is designed for the productive machining of parts for bars with a maximum diameter of either 16 mm or 20 mm. The machine comes standard with two electrospindles and with a rotary guide bush that is synchronized by pulleys and belts from the main spindle.

12 positions tool turret Baruffaldi for VDI 20 tools enables with Z4 axis to do two different turning operations at one time on the main spindle. Nine linear CNC axes (X1, X2, Y1, Y2, Y3, Z1, Z2, Z3, Z4) and two rotary axes (C1, C2) enables the use of 4 tools at the same time.



K'MX 632

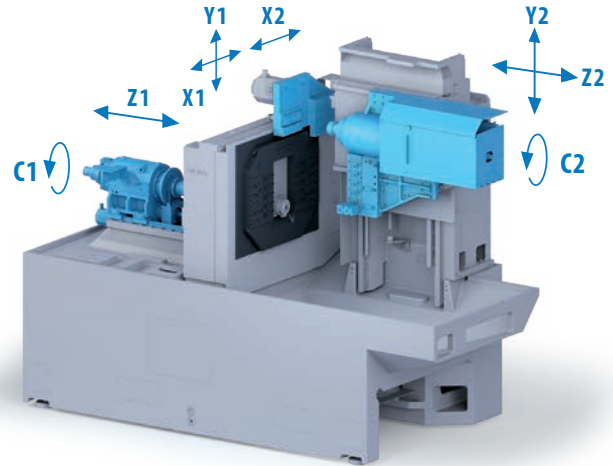
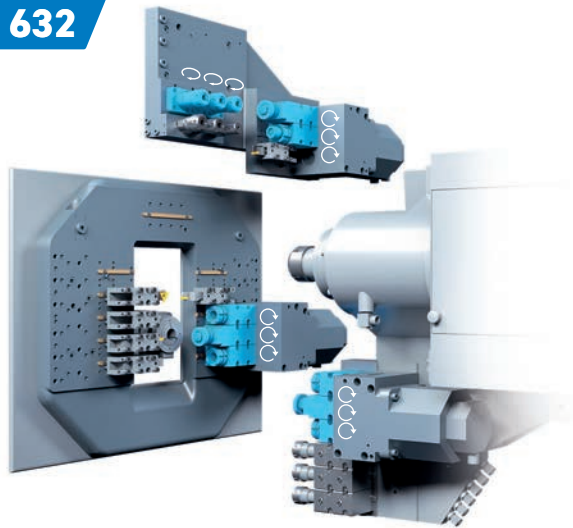

THE MANURHIN K'MX 632 is designed for productive machining of parts for bars with a maximum diameter of 32 mm. With a spindle bore diameter of 37 mm, no modification of the end of the bar for bar feeder collet is needed. The machine comes standard with two electrospindles, each with a maximum speed of 10,000 rpm and with a rotary guide bush, synchronized by pulleys and belts from the main spindle. Six linear axes (X1, X2, Y1, Y2, Z1, Z2), two rotary axes (C1, C2).

The machine is very strong when milling, with torque up to 32 Nm!

Specifications

Max. diameter of bar stock	Ø 32 (36)
Spindle bore	Ø 37
Spindle power 100 % / 25 % - main	5.5 / 7.5 kW
Spindle power 100 % / 30 min. - counter	3.7 / 5.5 kW
Spindle max. speed - main	10,000 rpm
Spindle max. speed - counter	10,000 rpm
Spindle stroke	410 mm
Number of CNC axes	6+2
Programming channels	2
Tools in cut at the same time max	2
Live tools power	2.3 kW

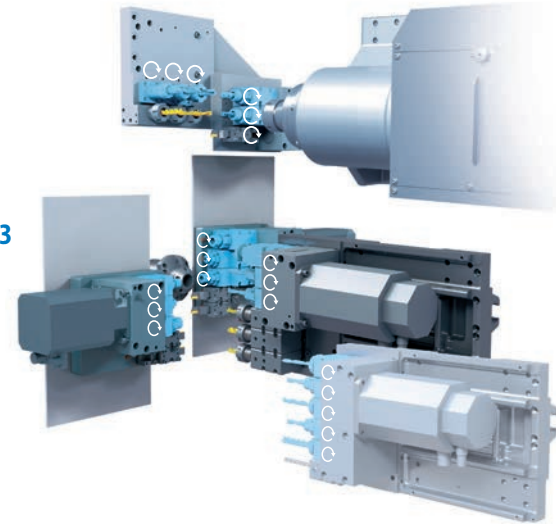
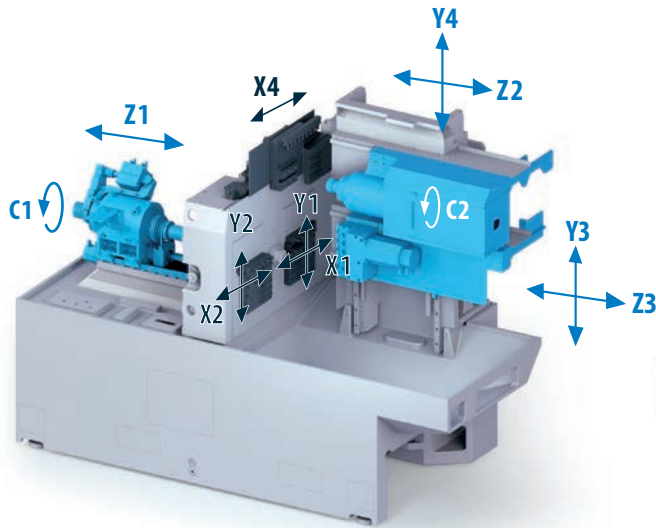

Specifications

Max. diameter of bar stock	Ø 32 (36)
Spindle bore	Ø 37
Spindle power 100 % / 25 % - main	15 / 25 kW
Spindle power 100 % / 30 min. - counter	3.7 / 5.5 kW
Spindle max. speed - main	8,000 rpm
Spindle max. speed - counter	10,000 rpm
Spindle stroke	410 mm
Number of CNC axes	10+2
Programming channels	3
Tools in cut at the same time max	4
Live tools power	2.3 kW

THE MANURHIN K'MX 1032 is delivered in two versions –one for bars Ø 32 mm and one for bars Ø 36 mm (bar preparation is needed). The highlight of the K'MX 1032 is the productivity. Up to 25 tools (including up to 17 powered tools) can be working simultaneously with 10 independent axes. Tool changes are quick and easy with the compatible tool holder cartridge system. The large door opening provides easy access to tools for operator. Ten linear CNC axes (X1, X2, X4, Y1, Y2, Y3, Y4, Z1, Z2, Z3) and two rotary axes (C1, C2) enables the use of 4 tools at the same time.



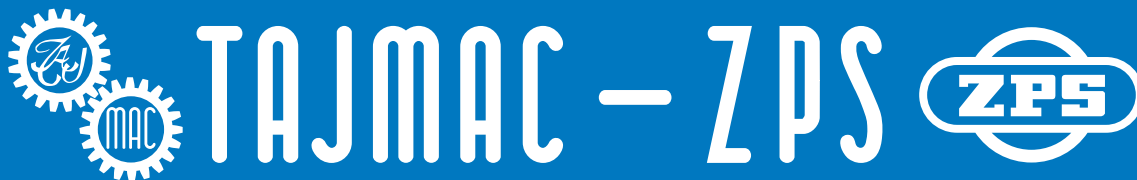

TAJMAC-ZPS, a. s. | třída 3. května 1180 | 763 02 Zlín, Malenovice | CZECH REPUBLIC
Phone: +420 577 532 072 | www.tajmac-zps.cz | e-mail: info@tajmac-zps.cz