

SERAPID
RIGID CHAIN TECHNOLOGY

MAKE YOUR DREAMS COME TRUE



“ I don't remember how we came across Serapid; possibly when hunting around for a technical precedent for what we wanted to propose, which existed, as far as we knew, only in theatre staging systems. What the Serapid team brought first was an incredible openness to taking on what, to most people, would have sounded like an impossible challenge: **to make a piece of public space move**. Where we would have expected every other company on earth to say "no, it's not possible", Serapid simply brought solid technical expertise and immediately set about demonstrating how it could not only be made possible, but completely plausible and reliable. ”

David Saxby **OO:/** Architects



Stage area formed from café roof.



Summer café.

HISTORY

SERAPID was founded in France in 1972. It designs and manufactures technology to move and transfer heavy loads: Rigid Chain Technology (RCT). From the start, the business designed products and bespoke solutions to solve problems encountered by the automobile industry, then the nuclear and aeronautical industries by offering precision, compactness and reliability.

In the 1980s it extended its activity throughout Europe and the United States. In parallel to its geographic expansion, SERAPID adapted, innovated and evolved its product for new markets. In 1996 SERAPID introduced RCT to theatre and show professionals. The LinkLift product was designed to meet scenery lifting needs. Today over 1000 sites around the world use this technology to lift and move stages and platforms.

In 2009 SERAPID developed RigiBelt, a totally non-magnetic belt designed for medical and pharmaceutical applications.

Since 2014 SERAPID has been using its skills to develop solutions to problems that are specific to kinetic architecture. When moving a structural element such as a wall, roof or room, raising or lowering a truck, a car or goods, Building DynamicS (BDS) offers a range of solutions specific to reconfiguring infrastructures and buildings.

SERAPID is permanently improving its product range and provides adapted and bespoke solutions for the most audacious projects.

For over 40 years the driving force behind the SERAPID team has been to support clients through all phases of their projects to ensure they are provided with effective solutions.

Export development, continuous innovation and the penetration of new markets make Serapid one of the key suppliers in the movement of loads.



WHAT IS THE COMMON FEATURE
AMONG THESE
ARCHITECTURAL WORKS?

SERAPID
RIGID CHAIN TECHNOLOGY





Sketch of F. Gehry

SAMPLE PROJECTS
ARCHITECTURE

FONDATION LOUIS VUITTON

Paris | France

Conceived by Franck Gehry, this glass building resembling a yacht with wind-filled sails is located at the crossroads of the Bois de Boulogne and the Jardin d'Acclimatation. This modern art museum is composed of 11 galleries and a 320 seat auditorium.

The auditorium hosts debates, conferences but also live shows, cinema or video. The space must therefore be transformable to meet the needs of the varying events.

The Serapid QSX system uses a sequence of vertical and rotational movements; to allow the auditorium to be automatically transformed from a clear hardwood floored area, which can be flat or tiered, to one of raked theatre seating. The design of the system allows seating to be either flat floor or a range of raked arrangements to suit specific events. The unique design allows for different floor finishes in the seating configuration and also conditioned air to be fed directly to each seat.





RISING TIDE BAR

Oasis of the Seas | Royal Caribbean Cruise Line

Located at the heart of the atrium the rising tide bar is the main attraction of this sea-going giant. Connecting the 5th and 8th decks, this «elevating» bar carries up to 35 passengers.

This technical challenge was met using SERAPID telescopic LinkLift elevator columns. The system's compactness made it possible to store the chains in a small space when the bar is in the low position. The 4 LinkLifts raise the passengers gently inside a moving ship. LinkLift rigid chains can raise a many tonnes over long distances, in this case a 40 tonne bar lifted over 10 metres, in complete safety.

Rigid chain technology can be used to achieve any feat and to realise your wildest dreams!





OLYMPIC GAMES

Beijing | China

A SERAPID LinkLift elevation system was selected for this exceptional event to equip the stage platforms for the opening ceremony in the Beijing National Stadium nicknamed «the Bird's Nest».

Ten platforms each with 56 tonne capacity and a total combined surface area of 1080 m² were raised using 62 LinkLift elevator columns. Each platform had scissor guides to guarantee stability at a height of 7 metres.

The ceremony was held on 08. 08. 2008 at 8:08 in the evening, 8 being the symbol for prosperity and infinity in Chinese culture. The event also contributed to the prosperity and long life of SERAPID rigid chain technology!





DUBAI MALL

Dubai | United Arab Emirates

Dubai Mall is one of the world's biggest shopping malls. An area at the heart of this complex is reserved entirely for events such as fashion shows or product launches.

Five large lifts, one with an integral revolve, make up a catwalk covering some 155m², allowing a variety of configurations and including provision for direct access from changing rooms below the mall on to the catwalk. The catwalks are lowered to ground level when not in use.

The 5 elevator platforms are covered with LED screens and glass panels that can support a load of 1 tonne/m². They are raised using SERAPID LinkLift elevator columns which were selected for their reliability, low noise levels, compactness of their machinery and their capacity to safely lift heavy loads.





SKYDECK

Willis Tower, Chicago | United States

SERAPID rigid chain technology was chosen for the "glass balconies" on the facade of the Willis Tower in Chicago so that they appear to be suspended in the sky. SERAPID rigid chains are used to safely extend 4 glass boxes from the tower's 103rd floor, which is at a height of 412 metres, to give visitors a unique experience.

Thanks to the SERAPID LinearBeam the 4 boxes can easily be retracted into the building structure in strong winds or for maintenance work. Rigid chain technology is reliable, silent and its reduced size allows it to be discretely built into the system.

These "glass balconies" called Skydecks attract over one million visitors every year.

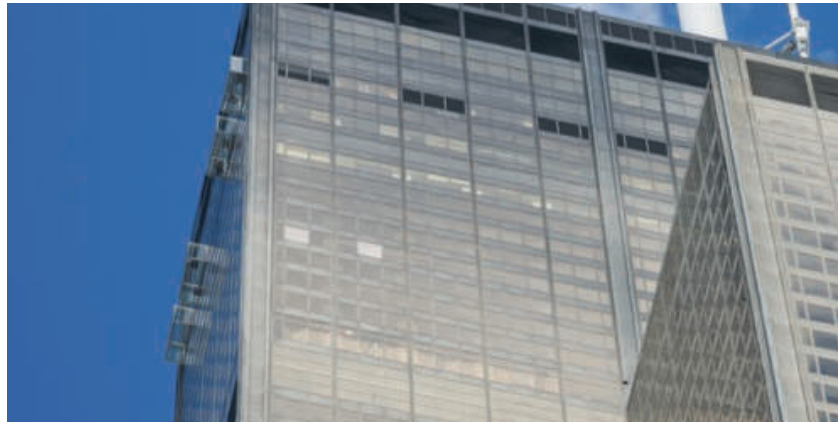



BOLSHOI THEATRE

Moscou | Russia

The prestigious Bolshoi stage is a world famous symbol of Moscow and Russia. After 6 years of refurbishment, the Bolshoi re-opened its historic stage in 2011.

SERAPID supplied several elevation systems for the main stage and the rehearsal room for the famous theatre. The 3 orchestra lift platforms for the main theatre and the 5 platforms for the rehearsal room were fitted with SERAPID LinkLift elevator columns. The LinkLift elevation system combines fluid movement, speed and low noise levels.

SERAPID's 40 years of experience in rigid chain technology make it one of today's leading players in stage and orchestra elevator technology, and in the stage scenery horizontal movement sector.



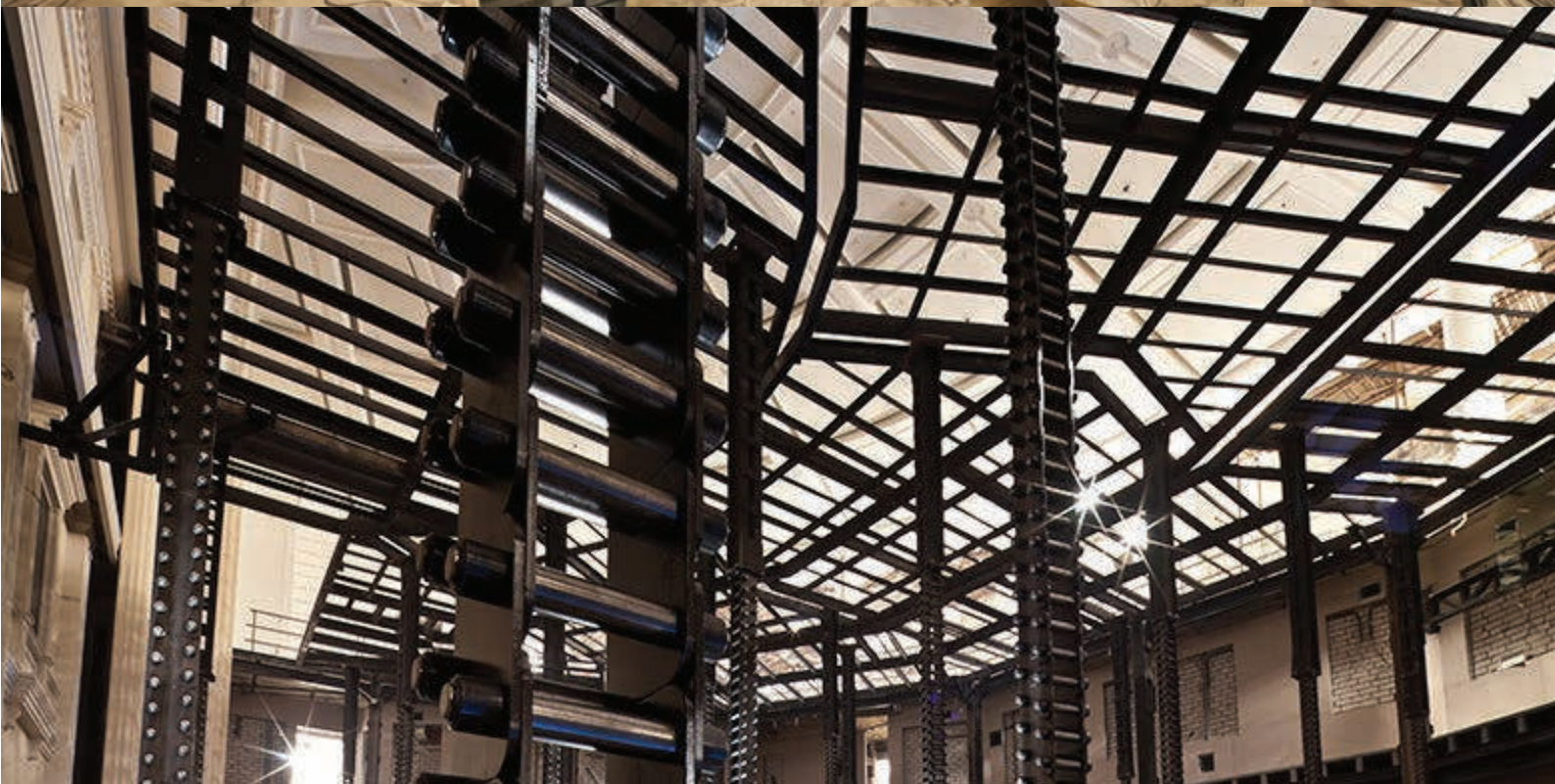

LINCOLN CENTER

New York | United States

The David H. Koch Theater is the venue that houses the New York City Ballet in the prestigious Lincoln Center for the Performing Arts. Originally named the New York State Theater, it was designed by architect Philip Johnson and built for the 1964–1965 World's Fair.

Renovation work began in July, 2008 with overall designs by JCJ Architecture with and Schuler Shook-Theatre Planners as theatre consultants.

Working with iWeiss – Theatrical Solutions, SERAPID designed, built and installed 3 new Orchestra Lift systems replacing the original pit filler system which allowed for the expansion of the orchestra pit to a total of 1,350 square feet.





SPORTS HUB

Republic of Singapore | Singapore

In order to solve issues relative to capacity and spectator interaction, the Singapore stadium opted for flexible stand configuration to be able to adapt to the needs of differing sports such as football, athletics, cricket, rugby, etc.

At the core of this system the SERAPID LinkLift rigid chain makes it possible to raise 43 different sized sections of stands weighing up to 110 tonnes. The SERAPID system can raise a section in 3 minutes, showing undeniable strength to quickly and easily reconfigure the stadium.

In addition to increasing the stadium's capacity for football, rugby and cricket events, the changes in configuration ensure that spectators are as close as possible to the action, enhancing their overall experience.



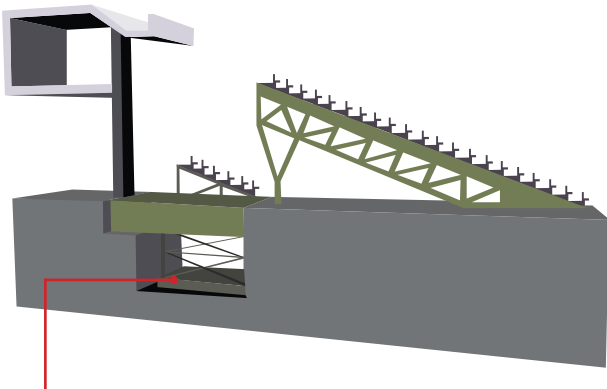
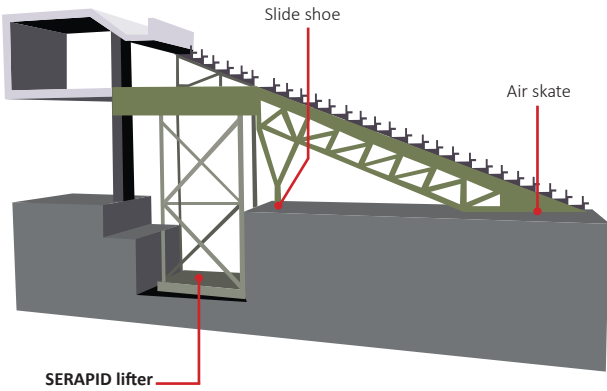

The **SERAPID lifter** will lower the two-concourse platform and seats down to ground level.

RETRACTABLE ROOF

Campo Pequeno Arena | Lisbon

Since 1892 the Campo Pequeno has been the main bull ring in Lisbon and an architectural icon. By the year 2000 the building had fallen in to a state of disrepair and it was decided that it should be restored. Use solely as a bull ring was not financially viable so a plan was formulated to make the building suitable for use not only as a bull ring, but also for concerts, circus and shows. As part of this there was a requirement for a roof that could be opened when bull fighting was taking place but could be closed for concerts and other similar events.

The central 36 metre diameter part of the roof is comprised of 8 segments, each weighing 7 tonnes.

The SERAPID LinearBeam actuators were chosen to move these segments. Designed to move heavy loads, the SERAPID rigid chain makes it possible to move and accurately position the heavy elements. The reliable and robust push-pull system was adapted to operate in an outdoor environment. Rigid Chain Technology makes it possible to think outside the box! It is robust and compact and adapts to all configurations, allowing it to move large structural elements over long distances.





BMW WELT

Munich | Germany

The BMW multi-purpose venue at BMW headquarters in Munich was designed to present the brand's latest models, organise meetings or put on cultural events.

The architect's objective was to create a single venue with maximum flexibility for different uses. SERAPID LinkLift columns meet this objective by providing a multitude of platform elevation and configuration possibilities. This allows the space to be converted from a perfectly flat floor for an exhibition, to a raked configuration for a show.

The auditorium is also equipped with 2 central elevators to bring vehicles up from the floor below for launches of new models during press conferences for example. SERAPID rigid chain technology allows multiple space configurations, platform elevation and venue transformation.





TRANSPORT ELEVATOR

Maxim Gorki Theatre | Berlin, Germany

This transport elevator is set in to the adjacent roadway and is designed to transport goods and stage scenery from street level to the theatre basement. The cabin roof is covered with 7.2 tonnes of cobblestones which form part of the street surface when the elevator is not in use. The cabin is raised so that goods can be lowered to the level beneath the street.

There were two recurring issues with the original elevator system in the past, poor reliability and high maintenance costs, which led to it being replaced.

Because of its strength and dependability the Serapid solution was chosen to replace the original system. The elevator system, comprised of 4 LinkLifts, was installed and has been running since 2007 with no failures and very little maintenance.





CAR LIFT

Londres | England

Located at a private residence in London, the lift in its 'parked' position forms part of the driveway of the house; with its structural roof finished in natural stone allowing a car to be parked on top. The lift is finished in architectural glass and black perforated steel giving it a modern and minimalist appearance. It can be raised to allow a car to be driven in to it and transported down to the underground garage. This can still be done even with a car parked on the roof of the lift, providing maximum flexibility for the parking and garaging of cars within the limited space available at the property.

LinkLift system is designed for an 8.5 metres stroke with speed of 120 mm/s. The Serapid lifting solution is machine roomless with all the drive system being located in the pit below the lift.

The lift offers all the benefits of a Serapid system, giving high and repeatable positioning accuracy, low noise, low maintenance and none of the problems associated with high capacity hydraulic lifts.





TRUCK LIFT

National Theatre Mannheim | Mannheim, Germany

Following repeated oil leakage problems and bearing failures in the previous hydraulic elevator system, the SERAPID solution was chosen to renovate this elevator platform.

The 31.5 tonne truck lift at the Manheim National Theatre is used to access 3 levels: the basement, ground floor and first floor.

LinkLift elevator columns, used in conjunction with simple linear guides were installed in the elevator pit. As this solution does not require a machine room, the existing machine room was cleared for use as a storage space.

The SERAPID LinkLift rigid chain is environmentally friendly and reliable, it requires very little maintenance and is easy to adapt to existing configurations in a refurbishment context.





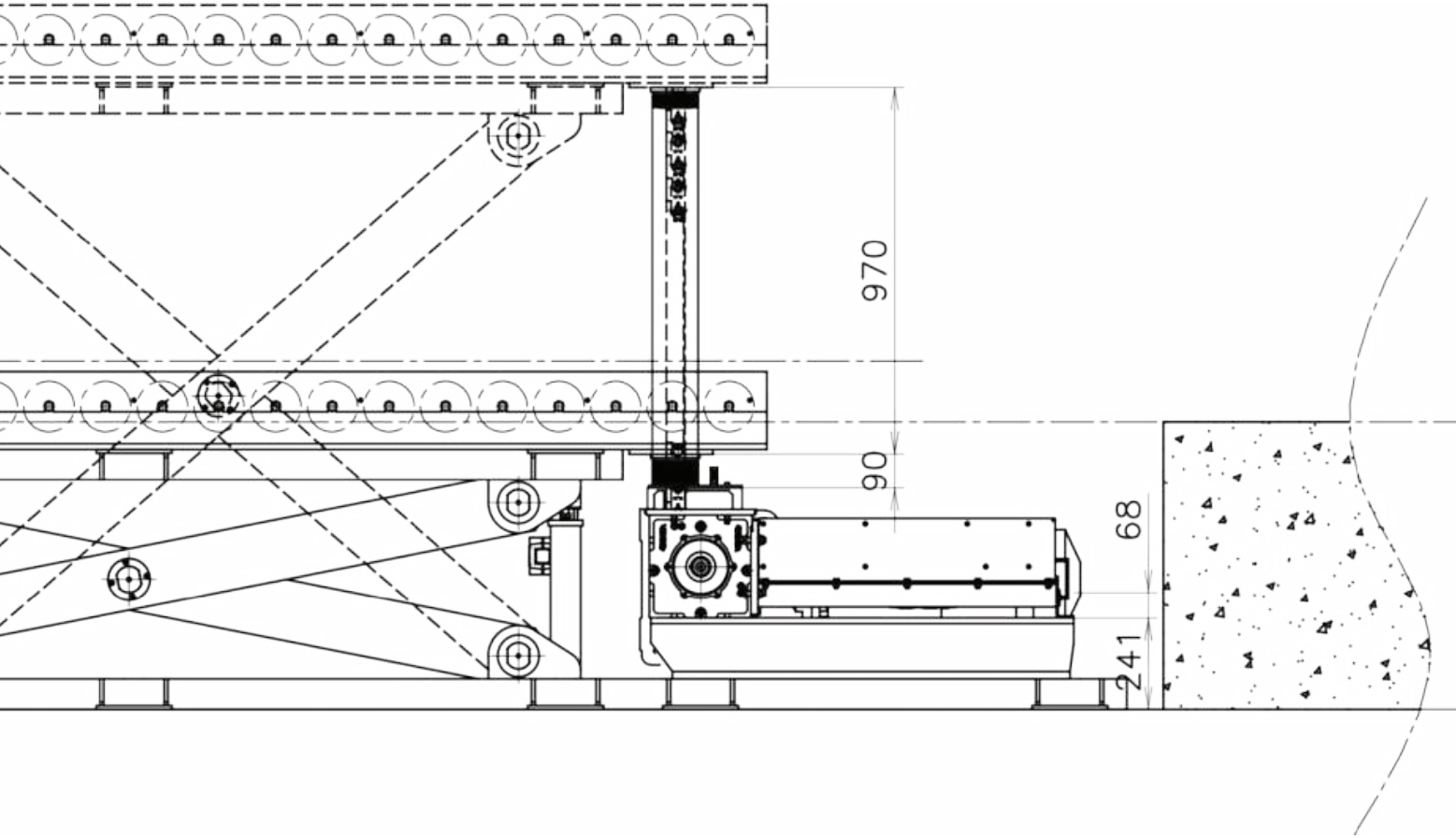

OUR OTHER MARKETS

OTHER MARKETS

AEROSPACE



AIR PLANE ASSEMBLY



METROLOGY

NUCLEAR



PUSHER CHAIN FOR PACKAGE TRANSFER HOODS

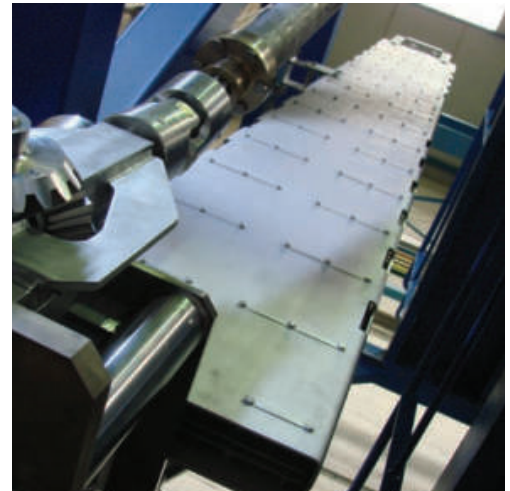

HORIZONTAL FUEL TRANSFER TO POOLS

TOOL HANDLING



QUICK DIE CHANGE

AUTOMOTIVE



LIFTING PLATFORMS

MEDICAL

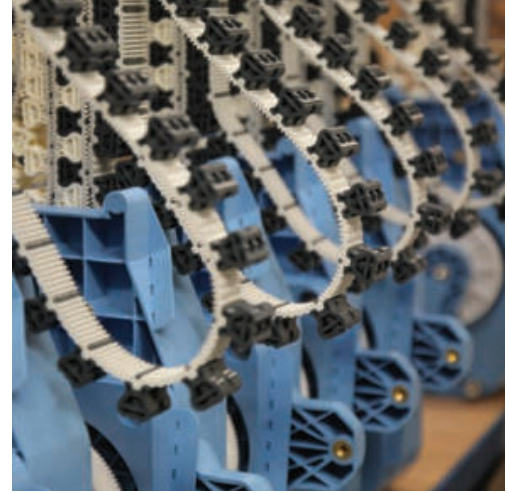

NON MAGNETIC ACTUATOR



PRESS DIE POSITIONING AND TRANSFER SYSTEM



HIGH PERFORMANCE ELEVATOR PLATFORMS



MRI TRANSFERT

RIGID CHAIN TECHNOLOGY

Simple and flexible technology

SERAPID has been working in the field of linear movement equipment for over 40 years. The SERAPID elevation and transfer systems are designed using a simple mechanical principle making it possible to transfer loads of a few kilograms to several hundred tonnes. They use rigid chain technology (RCT).

This technology is based on the use of interlocking chain links. When the chain is deployed in one plane it behaves like a true rigid pushing/pulling bar. In the other plane, the chain unlocks in the drive casing and stores in a reduced space.

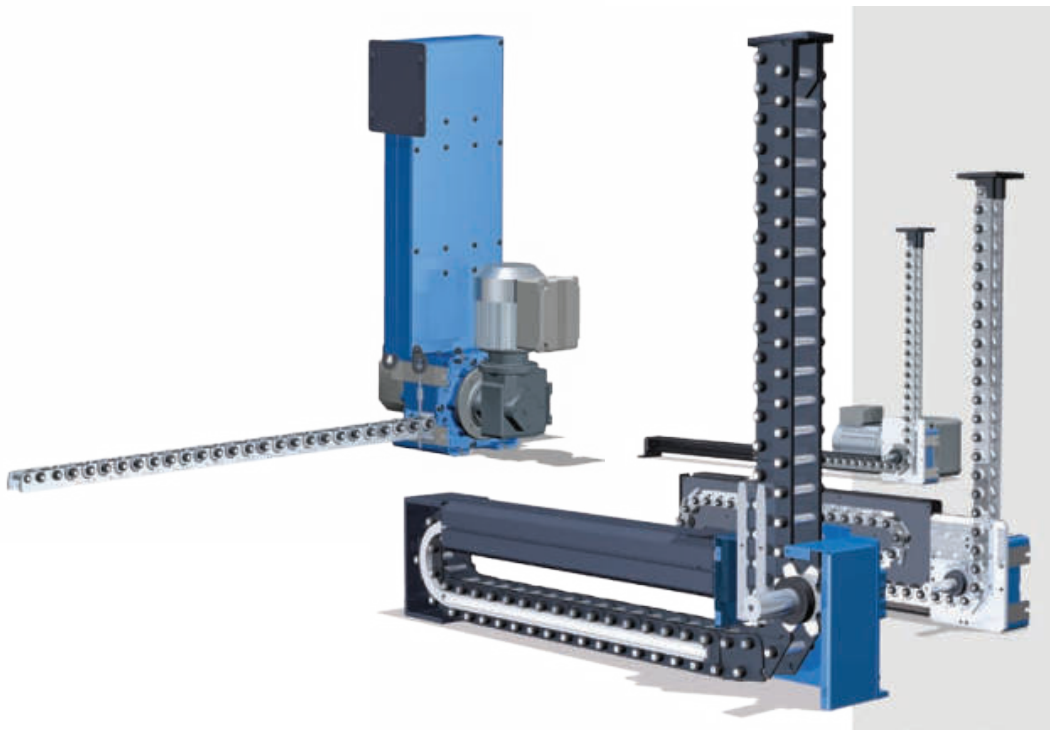

www.serapid.com

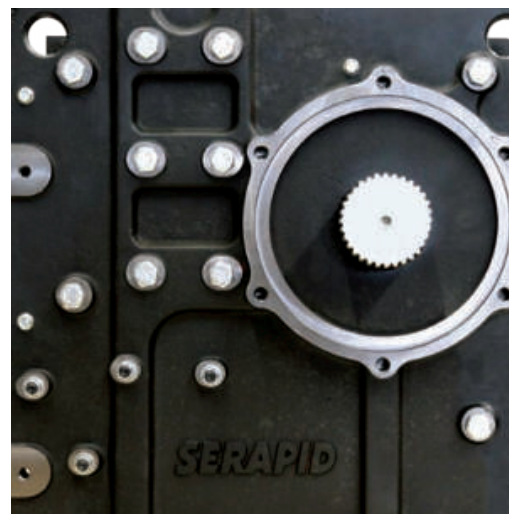
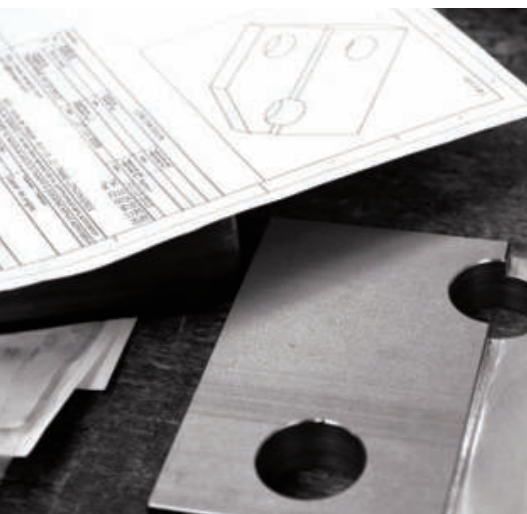
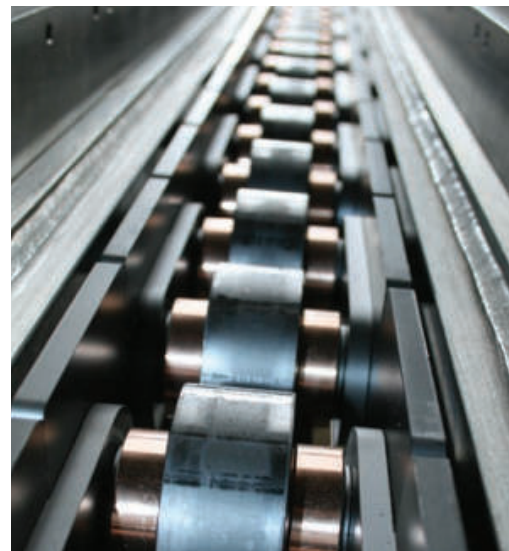
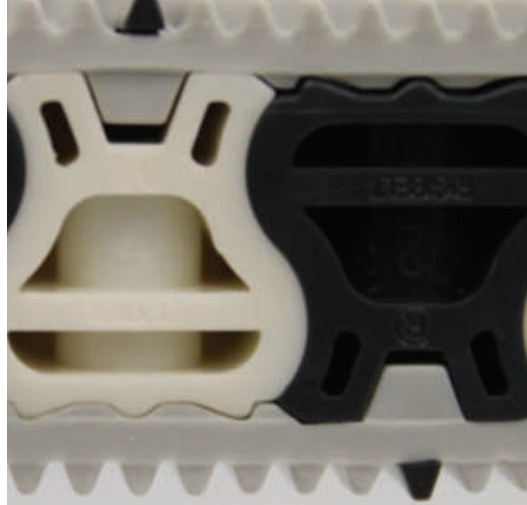
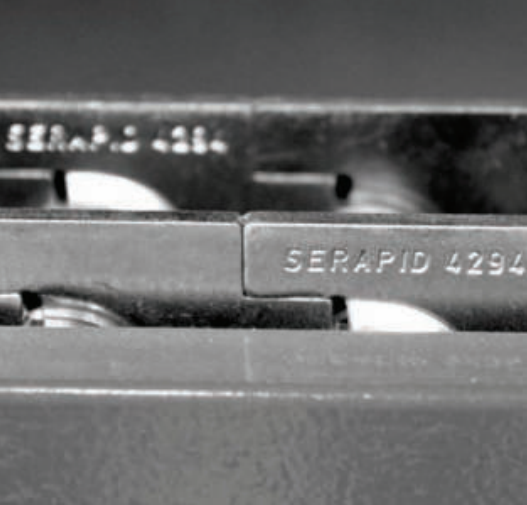

SERAPID

RIGID CHAIN TECHNOLOGY

www.serapid.com

SERAPID France

ZI Louis Delaporte, Zone Bleue, Voie F
F-76370 Rouxmesnil-Bouteilles | France
+33 (0)2 32 06 35 60
info-fr@serapid.com

SERAPID Ltd

Elm Farm Park, Great Green, Thurston,
Bury St Edmunds | IP31 3SH England
+44 (0)1359 233335
info-uk@serapid.com

SERAPID Deutschland GmbH

Wilhelm-Frank-Straße 30
D-97980 Bad Mergentheim | Deutschland
+49 (0)7931 9647-0
info-de@serapid.com

SERAPID USA INC.

34100 Mound Road
Sterling Heights MI 48310 | USA
+1 586 274 0774
info-us@serapid.com

SERAPID Italy Office | +39 01 18 00 35 44 | info-it@serapid.com · SERAPID China Office | +86 185 1215 0303 | info-cn@serapid.com
SERAPID Mexico Office / LATAM | +52 1 442 4 900 701 | info-mx@serapid.com